

**HD 6/12 G**  
**HD 6/15 G**  
**HD 7/20 G**  
**HD 8/23 G**  
**Service Manual**



<b>Preface</b>	<b>5</b>
<b>Safety instructions</b>	<b>5</b>
Symbols on the machine	6
Hazard levels	6
<b>Description in this service manual</b>	<b>6</b>
Service groups	6
Functional group structure	6
Textual description	6
<b>Technical Features</b>	<b>7</b>
Intended use	7
Field of application	7
Safety installations	8
Safety catch	8
Overflow valve	8
Safety valve	8
Thermostat valve	8
Type plate	8
<b>Overview of the appliance</b>	<b>9</b>
Explosion drawing of pump	10
Sectional view pump	11
Explosion drawing of pump head	12
Sectional view pump head	13
<b>AB Service group setup</b>	<b>14</b>
010 Safety information	14
General	14
020 Overview	14
Parts of the system	14
040 Service activities	15
ABRD Uninstall / install wheels	15
050 Maintenance and inspection	15
060 Error diagnosis	15
070 Peculiarities/ others	15
<b>AD Service group water system</b>	<b>16</b>
010 Safety information	16
General	16
020 Overview	16
Water system	16
030 Function	16
040 Service activities	17
ADWF Uninstalling / installing water filter	17
ADGW Uninstalling / installing casing water filter	17
050 Maintenance and inspection	17
060 Error diagnosis	17
070 Peculiarities/ others	17
<b>AE Service group pump</b>	<b>18</b>
010 Safety information	18
General	18
020 Overview	18
Pump	18
030 Function	18
040 Service activities	19
AEUV Uninstalling / installing the overflow valve	19

AEUP Checking the overflow valve	20
AEUE Adjusting the overflow valve	21
AESS Uninstalling / installing safety valve	21
AESP Checking the safety valve	22
AESE Adjusting the safety valve	22
AEDH Uninstalling / installing pressure retaining valve	23
AEDP Checking the pressure retaining valve	23
AETV Uninstalling / installing the thermostat valve	23
AETP Checking the thermostat valve	24
AEPK Uninstalling / installing pump head	24
AEPU Uninstalling / installing pump	25
AEVD Uninstalling / installing pressure valves	25
AEVS Uninstalling / installing suction valves	26
AEND Uninstalling / installing low-pressure seals	26
AEHD Uninstalling / installing high-pressure seals	27
AEKK Uninstalling / installing ceramic piston	29
AEOD Uninstalling / installing oil seals	30
050 Maintenance and inspection	36
AEOP Replacing the oil high-pressure pump	36
060 Error diagnosis	36
070 Peculiarities/ others	36
<b>AG Service group combustion engine</b>	<b>37</b>
010 Safety information	37
General	37
020 Overview	38
Internal combustion engine	38
040 Service activities	39
AGAB Uninstalling / installing sediment cup	39
AGAL Uninstalling /installing cover fan wheel	39
AGAT Uninstalling / installing muffler	39
AGDV Uninstalling /installing seal valve cover	40
AGKT Uninstalling / installing fuel tank	40
AGLF Uninstalling / installing air filter	41
AGLG Uninstalling / installing casing of the air filter	41
AGML Uninstalling / installing engine mount	41
AGSF Uninstalling / installing fine sieve fuel tank	42
AGSG Uninstalling / installing coarse sieve fuel tank	42
AGVG Uninstalling / installing carburettor	42
AGZK Uninstalling / installing spark plug	43
AGZS Uninstalling / installing ignition coil	43
050 Maintenance and inspection	45
AGMO Changing the engine oil	45
Setting the motor rpm	45
Setting the idling speed	45
Cleaning the sediment cup	46
Check spark plug	46
Carburettor modification for operation in higher altitudes	47
Carburettor modification	47
Use of fuel with additives	48
060 Error diagnosis	48
070 Peculiarities/ others	48
<b>AH Service group electrics</b>	<b>49</b>
010 Safety information	49
General	49
020 Overview	49
Electrical system	49
040 Service activities	50
AHMS Uninstalling / installing starter	50
AHRE Uninstalling / installing relay low oil level	50
050 Maintenance and inspection	50

060 Error diagnosis	50
070 Peculiarities/ others	50
<b>Technical Documentation</b>	<b>51</b>
Technical specifications	51
Maintenance overview report	52
Special tools	52
Circuit diagram	54

## Preface

Good service work requires extensive and practice-oriented training as well as well-structured training materials. Hence we offer regular basic and advanced training programmes covering the entire product range for all service engineers.

In addition to this, we also prepare service manuals for important appliances - these can be initially used as instruction guides and later on as reference guides.

Apart from this, we also regular information about product enhancements and their servicing.

If you should require supplements, have corrections or questions regarding this document, please address these citing the following subject to:

*international-service@de.kaercher.com*

Subject:	<b>Fall 118200</b>
----------	--------------------

The responsible product specialist will take care of your issue.

**Copying and duplication of texts and diagrams as well as third-party access to this information is permitted only with the explicit permission of the company:**

**Alfred Kärcher GmbH & Co. KG**  
**P O Box 160**  
**D -71349 Winnenden**  
**www.kaercher.com**

## Safety instructions

Service and maintenance tasks may only be performed by qualified and specially trained specialists.

### Observe safety information in the chapters!

- Please read the operating instructions for your machine before using it, and pay particular attention to the following safety instructions.
- Warning and information plates on the machine provide important directions for safe operation.
- Apart from the notes contained herein the general safety provisions and rules for the prevention of accidents of the legislator must be observed.

### **⚠ DANGER**



- *Switch off the appliance and, in case of appliances connected to the mains, pull out the power cord before cleaning and performing any maintenance tasks on the machine.*
- *Relieve the high pressure system of all pressure prior to all work on the appliance and the accessories.*
- *Maintenance work may only be carried out by approved customer service outlets or experts in this field who are familiar with the respective safety regulations.*
- *Mobile industrial appliances are subject to safety inspections according to the local regulations (for e.g. the following are applicable in Germany: VDE 0701).*
- *To avoid risks, all repairs and replacement of spare parts may only be carried out by the authorised customer service personnel.*
- *Only use accessories and spare parts which have been approved by the manufacturer. The exclusive use of original accessories and original spare parts ensures that the appliance can be operated safely and trouble free.*
- *Only use the fuels specified in the Operations Manual. Risk of explosion due to the use of inappropriate fuels.*
- *In petrol engine appliances, ensure that no petrol comes in contact with hot surfaces.*
- *Ensure that there is adequate ventilation or provision for diverting the exhaust gas while operating the appliance in closed rooms (risk of poisoning).*
- *Do not close the exhaust.*
- *Please ensure that there are no exhaust emissions near the air inlets.*
- *Do not use high pressure cleaners when there has been an oil spill; move the appliance to another spot and avoid any sort of spark formation.*
- *Do not store, spill or use fuel in the vicinity of open flames or appliances such as ovens, boilers, water heaters, etc. that have an ignition flame or can generate sparks.*

- *Do not use unsuitable fuels, as they may be dangerous.*
- *Keep even mildly inflammable objects and materials away from the muffler (at least 2 m).*
- *Do not start the engine without the muffler; check, clean and replace, if required, the muffler at regular intervals.*
- *Do not use the engine in forest, bushes or grassy areas without fitting a spark receiver at the exhaust*
- *Except for setting jobs, do not run the engine when the air filter is removed or there is no cover over the suction support.*
- *Do not make any adjustments to the regulator springs, regulator bars or other parts that can bring forth an increase in the engine speed.*
- *Risk of burns! Do not touch hot mufflers, cylinders or radiator ribs.*
- *Do not put hands or feet close to moving or rotating parts.*
- *Risk of poisoning! The appliance should not be operated in closed rooms.*

### **⚠ WARNING**

- *Do not bend over the exhaust or touch it.*

## Symbols on the machine

 <p>Protect from frost! Vor Frost schützen!</p>	<p>High-pressure jets can be dangerous if improperly used. The jet may not be directed at persons, animals, live electrical equipment or at the appliance itself.</p>
	<p>According to applicable regulations, the appliance must never be used on the drinking water net without a system separator. A suitable system separator by KÄRCHER or alternatively a system separator according to EN 12729 type BA must be used. Water that was flowing through a system separator is considered non-drinkable.</p>
	<p>The appliance contains hot surfaces that can lead to burn injuries.</p>

## Hazard levels

### **⚠ DANGER**

For an immediate danger which can lead to severe injuries or death.

### **⚠ WARNING**

For a possibly dangerous situation which could lead to severe injuries or death.

### **⚠ CAUTION**

For a possibly dangerous situation which can lead to minor injuries or property damage.

### **ATTENTION**

Pointer to a possibly dangerous situation, which can lead to property damage.

### **Note**

Indicates useful tips and important information.

## Description in this service manual

### Service groups

#### **Example:**

Install/uninstall ANRA wheel axle

AN	RA	Install/uninstall wheel axle
Service group	Component	Activity

Observe the allocation of service groups to the appliance components in the overview diagram in Chapter "Overview over the service and functional groups".

## Functional group structure

<b>010</b>	Safety instructions
<b>020</b>	Overview
<b>030</b>	Function
<b>040</b>	Service activities
<b>050</b>	Maintenance and inspection
<b>060</b>	Error diagnosis
<b>070</b>	Peculiarities/ others
<b>080 - 100</b>	Not assigned

## Textual description

➔ Instruction

■ Preparatory operations

1

2 Key numerical

A

B Key alphanumerical

– Enumeration / General list

⚠ **Safety note**

Pointer to hazards, sources of errors.

## Technical Features

- Water inlet with large water filter
- Hot water inlet up to 60 °C max
- Engine switch
- Thermostat valve
- Devices with petrol engine (depending on device version with 200 cm<sup>3</sup>, 250 cm<sup>3</sup> or 300 cm<sup>3</sup>)
- 3-piston crankshaft pump, piston (diameter = 18 mm) with ceramic sleeves
- Pump head made of brass
- Suction and high-pressure valves made of stainless steel
- Overflow valve
- Trigger gun
- Spray lance (850 mm)
- Power nozzle (stainless steel)
- High pressure hose (10 m)
- Rotary coupling
- Compact frame
- Pneumatic tires
- Storage compartment for small parts
- Holder for rotary nozzle

## Intended use

Mobile cold water high-pressure cleaner in different performance categories for commercial use.

Use this high pressure cleaner exclusively for

- for cleaning using high pressure jet without detergent (e.g. cleaning of facades, terraces, garden machines, vehicles).

For stubborn dirt, we recommend the use of the dirt blaster as a special accessory.

## Field of application

This service manual describes the appliance family:

- HD 6/12 G
- HD 6/15 G
- HD 7/20 G
- HD 8/23 G

Representative for all devices, the device HD 6/15 G with 200 cm<sup>3</sup> engine is described in this service manual.

Appliance type	Appliance no.	Operating instructions	Spare parts list
HD 6/12 G *JP (design version for Japan)	1.187-001.0	5.965-370.0	9.761-469.0
HD 6/15 G *KAP	1.187-002.0	5.965-370.0	9.761-470.0
HD 6/15 G *EU (with high-quality Kärcher accessories)	1.187-003.0	5.965-370.0	9.761-471.0
HD 7/20 G *KAP	1.187-004.0	5.965-370.0	9.761-472.0
HD 7/20 G *EU (with high-quality Kärcher accessories)	1.187-005.0	5.965-370.0	9.761-473.0
HD 8/23 G *KAP	1.187-006.0	5.965-370.0	9.761-474.0
HD 8/23 G *EU (with high-quality Kärcher accessories)	1.187-007.0	5.965-370.0	9.761-475.0

## Safety installations

Safety devices serve to protect the user and must not be rendered in operational or their functions bypassed.

**Observe safety information in the chapters!**

### Safety catch

The safety catch on the trigger gun prevents the appliance from being switched on unintentionally.

### Overflow valve

If the hand spray gun is closed, the overflow valve opens and the entire water volume will flow back to the pump suction side.

The overflow valve is set by the manufacturer and sealed. Setting only by customer service.

### Safety valve

The safety valve opens when the overflow valve is defective.

The safety valve is set by the manufacturer and sealed. Setting only by customer service.

### Thermostat valve

The thermal valve protects the high-pressure pump from unacceptable heating during circuit operation.

## Type plate

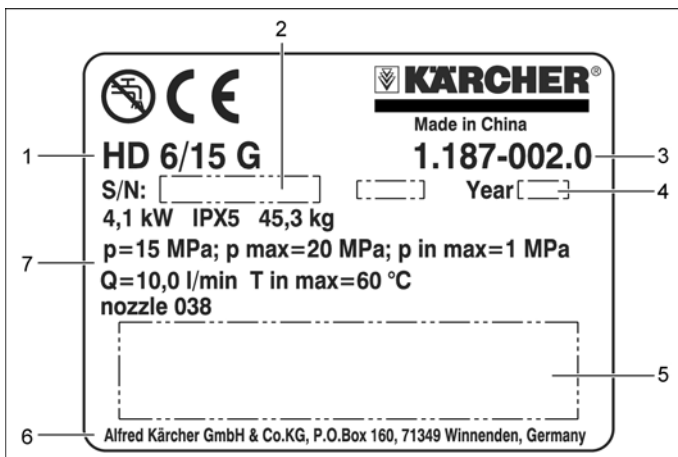

The type plate is located on the frame, next to the engine.

- 1 Appliance description
- 2 Serial number
- 3 Part number
- 4 Year of manufacture
- 5 Bar code. Contains part and serial number.
- 6 Address of manufacturer
- 7 Specifications



## Overview of the appliance

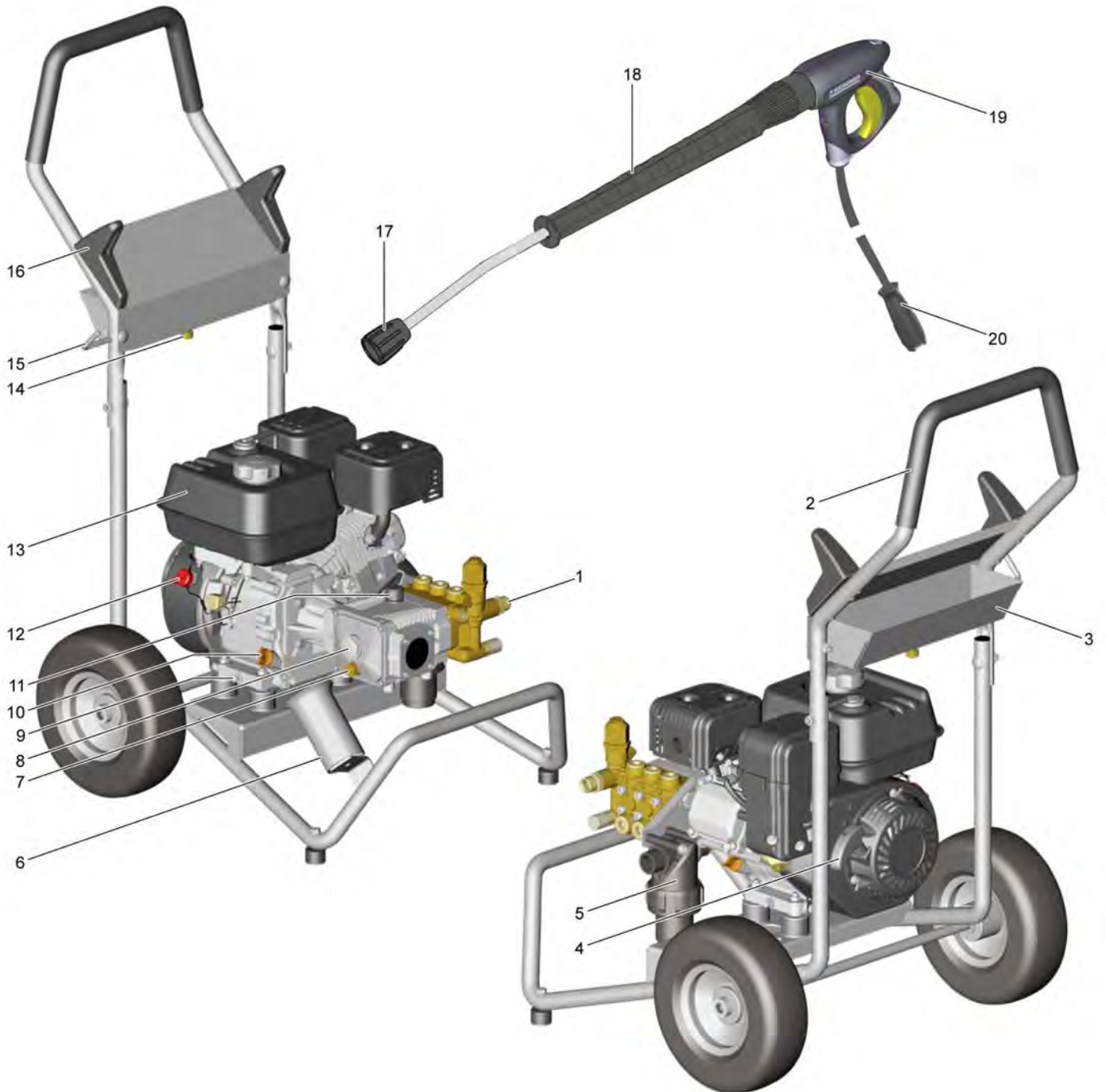

- 1 High pressure connection
- 2 Push handle
- 3 Storage compartment
- 4 Device for manual start
- 5 Water connection with filter
- 6 Storage for spray pipe
- 7 Oil drain screw pump
- 8 Oil level indicator pump
- 9 Oil drain screw engine
- 10 Oil filling screw engine
- 11 Dipstick pump
- 12 Engine switch

- 13 Fuel tank
- 14 Holder for rotary nozzle
- 15 Trigger gun storage clip
- 16 Hose switch
- 17 Nozzle, nozzle screws
- 18 Spray lance
- 19 Trigger gun
- 20 High pressure hose

### Note

The push handle can be removed, however, it cannot be folded down.

## Explosion drawing of pump

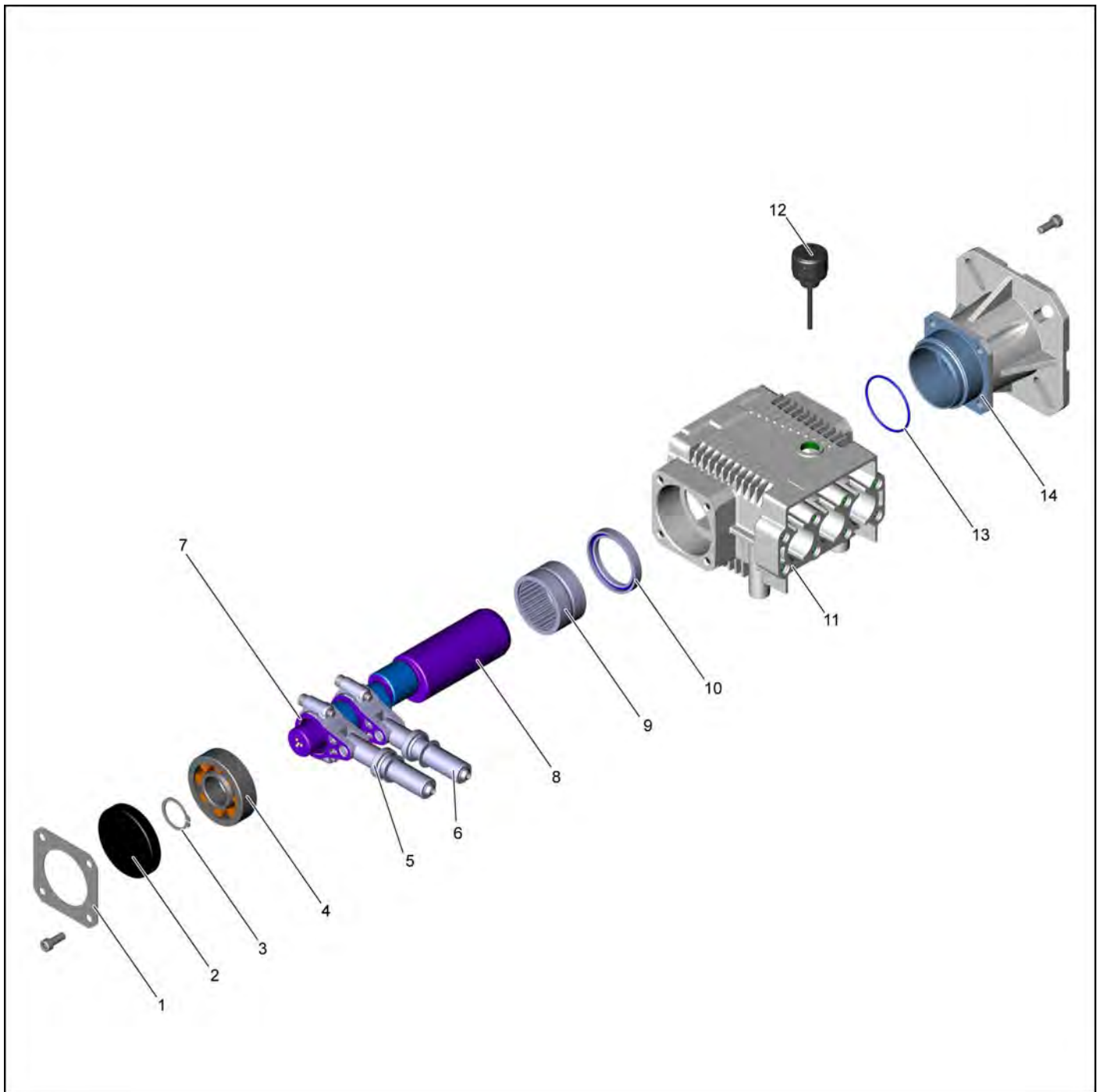

- 1 Cover
- 2 Bearing cover
- 3 Safety ring
- 4 Ball bearing
- 5 Low-pressure seal package
- 6 Ceramic piston
- 7 Connecting rod with piston rod

- 8 Crankshaft
- 9 Needle bearing
- 10 Washer ring
- 11 Pump casing
- 12 Oil fill screw
- 13 O ring
- 14 Flange

## Sectional view pump

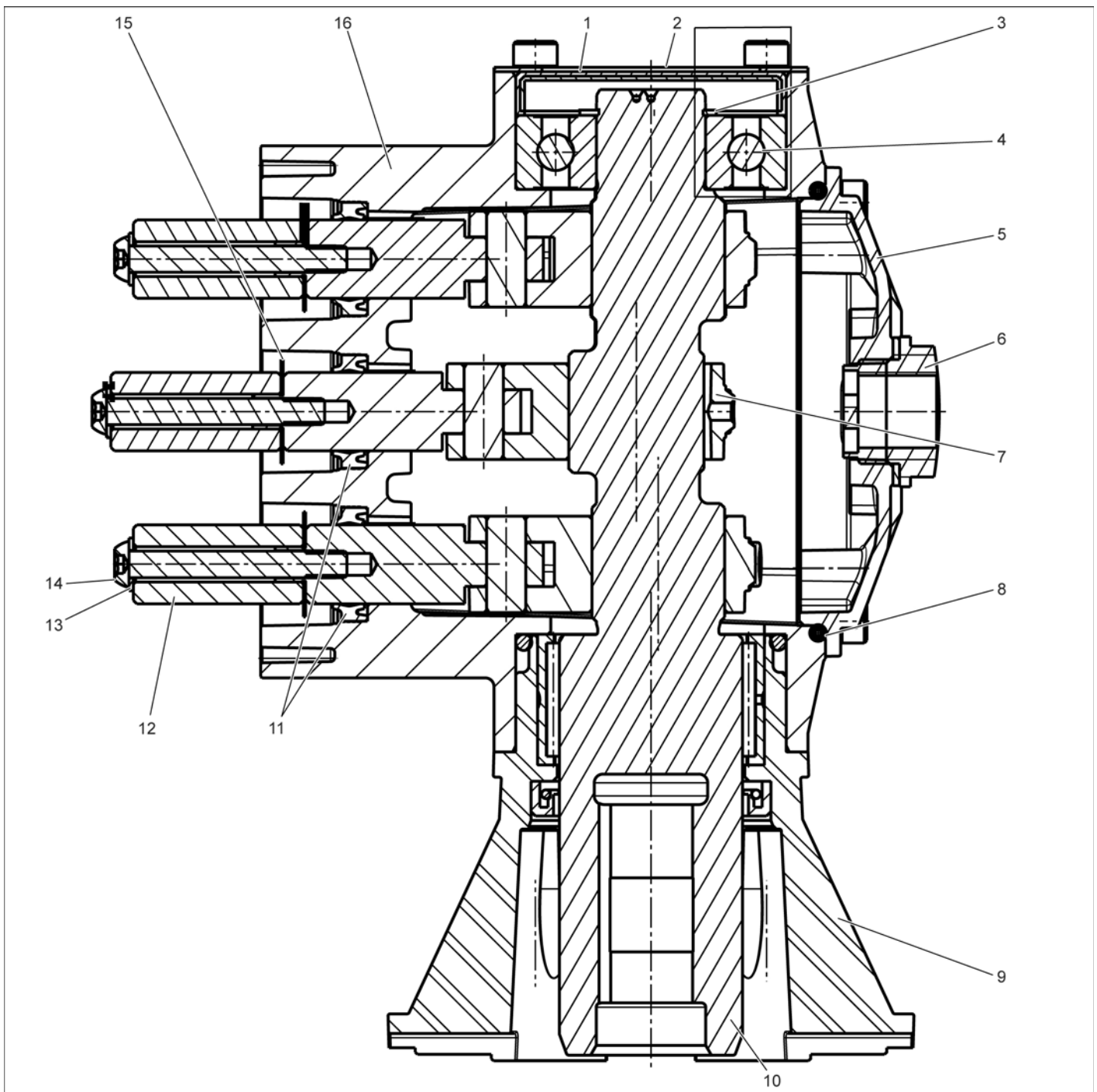

- 1 Bearing cover
- 2 Cover
- 3 Safety ring
- 4 Ball bearing
- 5 Cover
- 6 Oil level indicator
- 7 Connecting rod with piston rod
- 8 Seal

- 9 Flange
- 10 Crankshaft
- 11 Oil seal
- 12 Ceramic piston
- 13 Washer
- 14 Screw
- 15 Copper disc
- 16 Pump casing

## Explosion drawing of pump head

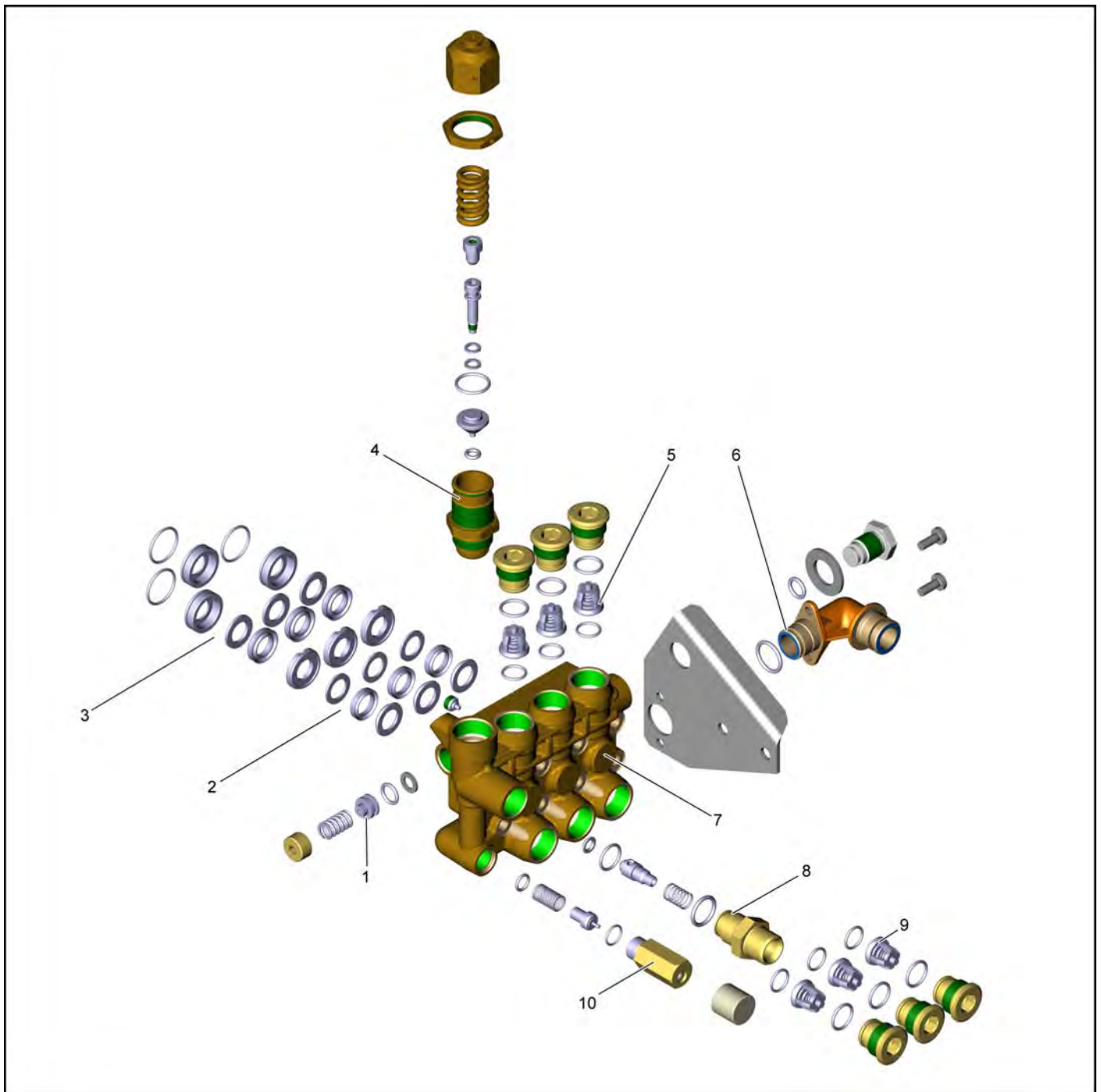

- 1 Safety valve
- 2 High-pressure seal packages
- 3 Low-pressure seal packages
- 4 Overflow valve
- 5 Pressure valve

- 6 Water connection
- 7 Pump head
- 8 Pressure holding valve
- 9 Suction valve
- 10 Thermostat valve

## Sectional view pump head

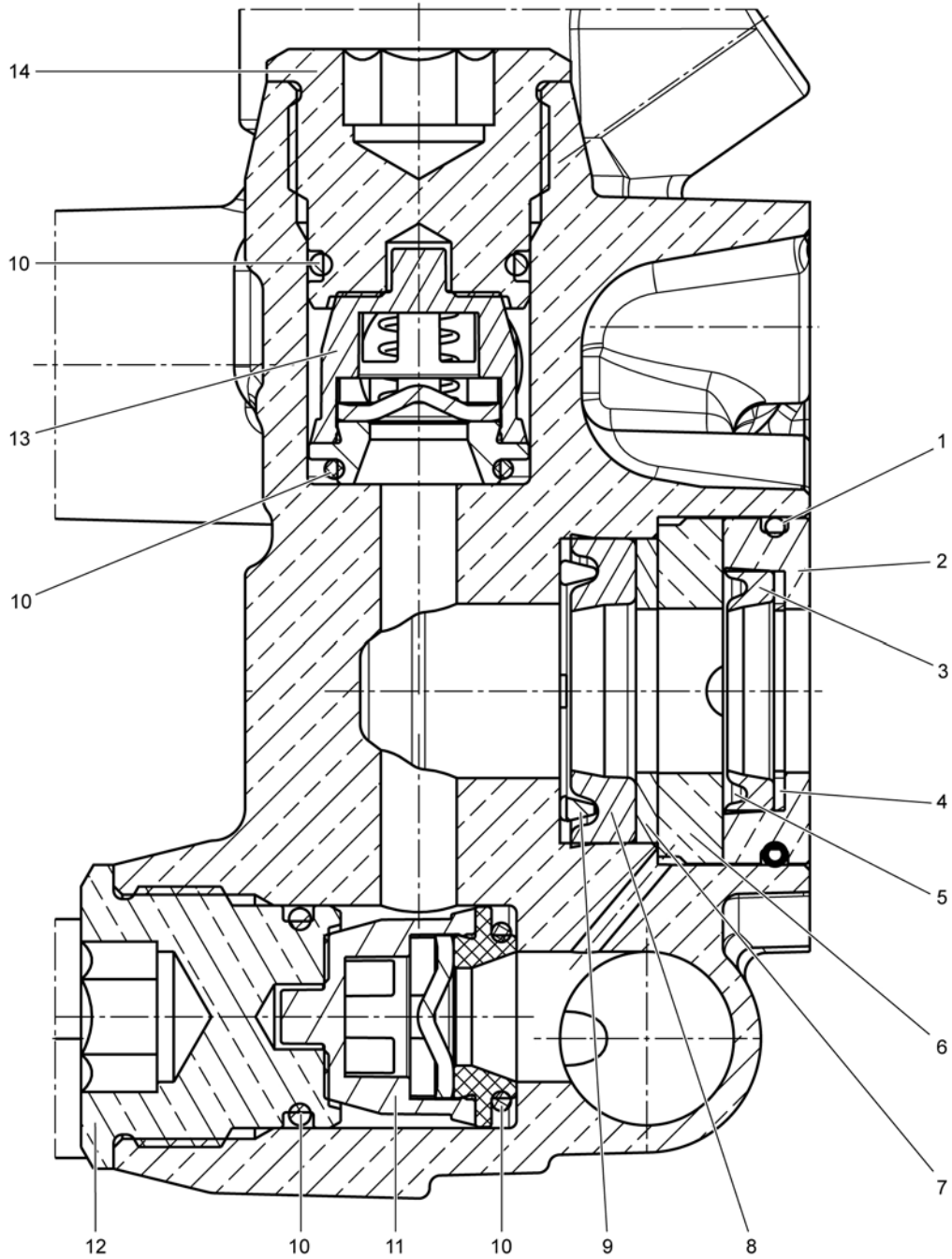

- 1 O ring
- 2 Brass sleeve
- 3 Washer ring
- 4 Disc
- 5 Spreader ring
- 6 Brass disc
- 7 Disc
- 8 Washer ring
- 9 Spreader ring

- 10 O ring
- 11 Suction valve
- 12 Valve screw
- 13 Pressure valve
- 14 Valve screw

- 3 - 5 low-pressure sealing packages
- 7 - 9 high-pressure sealing packages

## AB Service group setup

### 010 Safety information

#### General

Observe general safety information!

Service and maintenance tasks may only be performed by qualified and specially trained specialists.

#### **⚠ DANGER**

- Switch off the appliance and, in case of appliances connected to the mains, pull out the power cord before cleaning and performing any maintenance tasks on the machine.
- Relieve the high pressure system of all pressure prior to all work on the appliance and the accessories.
- Maintenance work may only be carried out by approved customer service outlets or experts in this field who are familiar with the respective safety regulations.
- To avoid risks, all repairs and replacement of spare parts may only be carried out by the authorised customer service personnel.
- Only use accessories and spare parts which have been approved by the manufacturer. The exclusive use of original accessories and original spare parts ensures that the appliance can be operated safely and trouble free.

### 020 Overview

#### Parts of the system



ABRD Uninstall / install wheels

## 040 Service activities

### Note

Unless otherwise described, the installation takes place in reverse order.

### ABRD Uninstall / install wheels

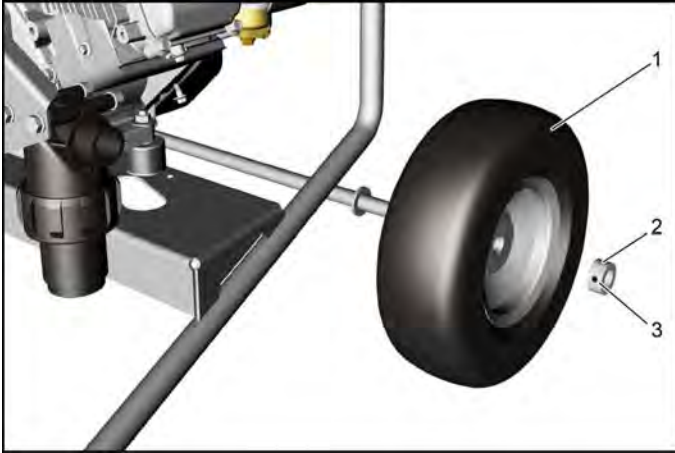

- 1 Wheel
- 2 Safety ring
- 3 Screw

- ➔ Loosen the screw.
- ➔ Remove the safety ring.
- ➔ Lift the appliance.
- ➔ Remove wheel.

Tyre pressure	bar / psi
Wheel	2,0 / 30

## 050 Maintenance and inspection

Service group does not contain any maintenance and inspection points.

## 060 Error diagnosis

The service group does not contain any error diagnosis.

## 070 Peculiarities/ others

The service group does not contain any peculiarities.

## AD Service group water system

### 010 Safety information

#### General

Observe general safety information!

Service and maintenance tasks may only be performed by qualified and specially trained specialists.

#### **⚠ DANGER**

- Switch off the appliance and, in case of appliances connected to the mains, pull out the power cord before cleaning and performing any maintenance tasks on the machine.
- Relieve the high pressure system of all pressure prior to all work on the appliance and the accessories.
- Maintenance work may only be carried out by approved customer service outlets or experts in this field who are familiar with the respective safety regulations.
- To avoid risks, all repairs and replacement of spare parts may only be carried out by the authorised customer service personnel.
- Only use accessories and spare parts which have been approved by the manufacturer. The exclusive use of original accessories and original spare parts ensures that the appliance can be operated safely and trouble free.

### 020 Overview

#### Water system



ADGW Uninstalling / installing casing water filter

ADWF Uninstalling / installing water filter

### 030 Function

The water filter traps the dirt particles.

Dirt particles in the water lead to a high level of wear of the valves, the overflow valve and the seals.

The water filter has a mesh size of 100 or 150 µm.



## 040 Service activities

### Note

Unless otherwise described, the installation takes place in reverse order.

### ADWF Uninstalling / installing water filter

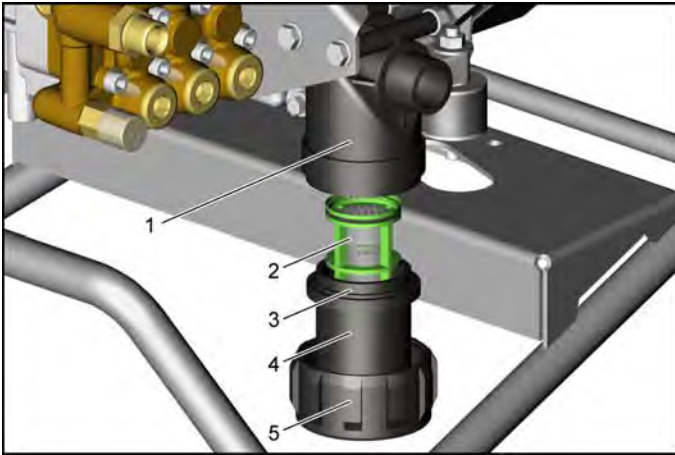

- 1 Casing water filter
- 2 Water filter
- 3 O ring
- 4 Filter pot
- 5 Screws of the filter cups

- ➔ Unscrew the screw connection of the filter cup.
- ➔ Remove the filter cup towards the bottom.
- ➔ Pull the water filter out towards the bottom.

### Note

Check O-ring for damage.  
Clean the intake and sealing areas.

### ADGW Uninstalling / installing casing water filter

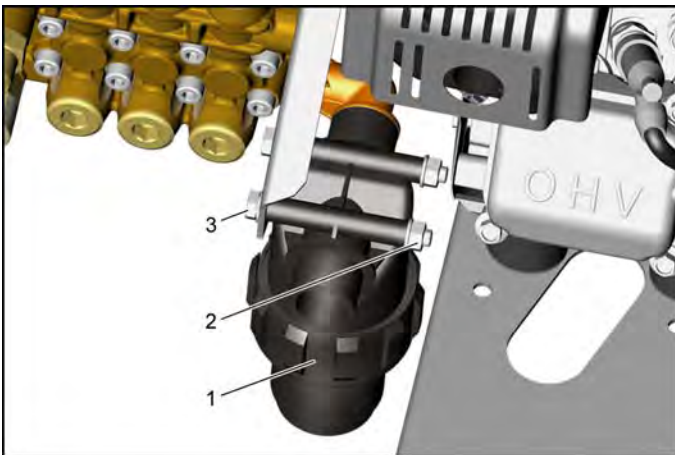

### ■ ADWF Uninstalling / installing water filter

- 1 Casing water filter
- 2 Nuts
- 3 Screws

- ➔ Loosen the mounting nuts.
- ➔ Pull out the screws
- ➔ Remove casing of the water filter.

### Note

Check O-ring for damage.  
Clean the intake and sealing areas.

## 050 Maintenance and inspection

Service group does not contain any maintenance and inspection points.

## 060 Error diagnosis

The service group does not contain any error diagnosis.

## 070 Peculiarities/ others

The service group does not contain any peculiarities.

## AE Service group pump

### 010 Safety information

#### General

Observe general safety information!

Service and maintenance tasks may only be performed by qualified and specially trained specialists.

#### **⚠ DANGER**

- Switch off the appliance and, in case of appliances connected to the mains, pull out the power cord before cleaning and performing any maintenance tasks on the machine.
- Relieve the high pressure system of all pressure prior to all work on the appliance and the accessories.
- Maintenance work may only be carried out by approved customer service outlets or experts in this field who are familiar with the respective safety regulations.
- To avoid risks, all repairs and replacement of spare parts may only be carried out by the authorised customer service personnel.
- Only use accessories and spare parts which have been approved by the manufacturer. The exclusive use of original accessories and original spare parts ensures that the appliance can be operated safely and trouble free.
- Ensure that there is adequate ventilation or provision for diverting the exhaust gas while operating the appliance in closed rooms (risk of poisoning).
- Do not close the exhaust.

### 020 Overview

#### Pump

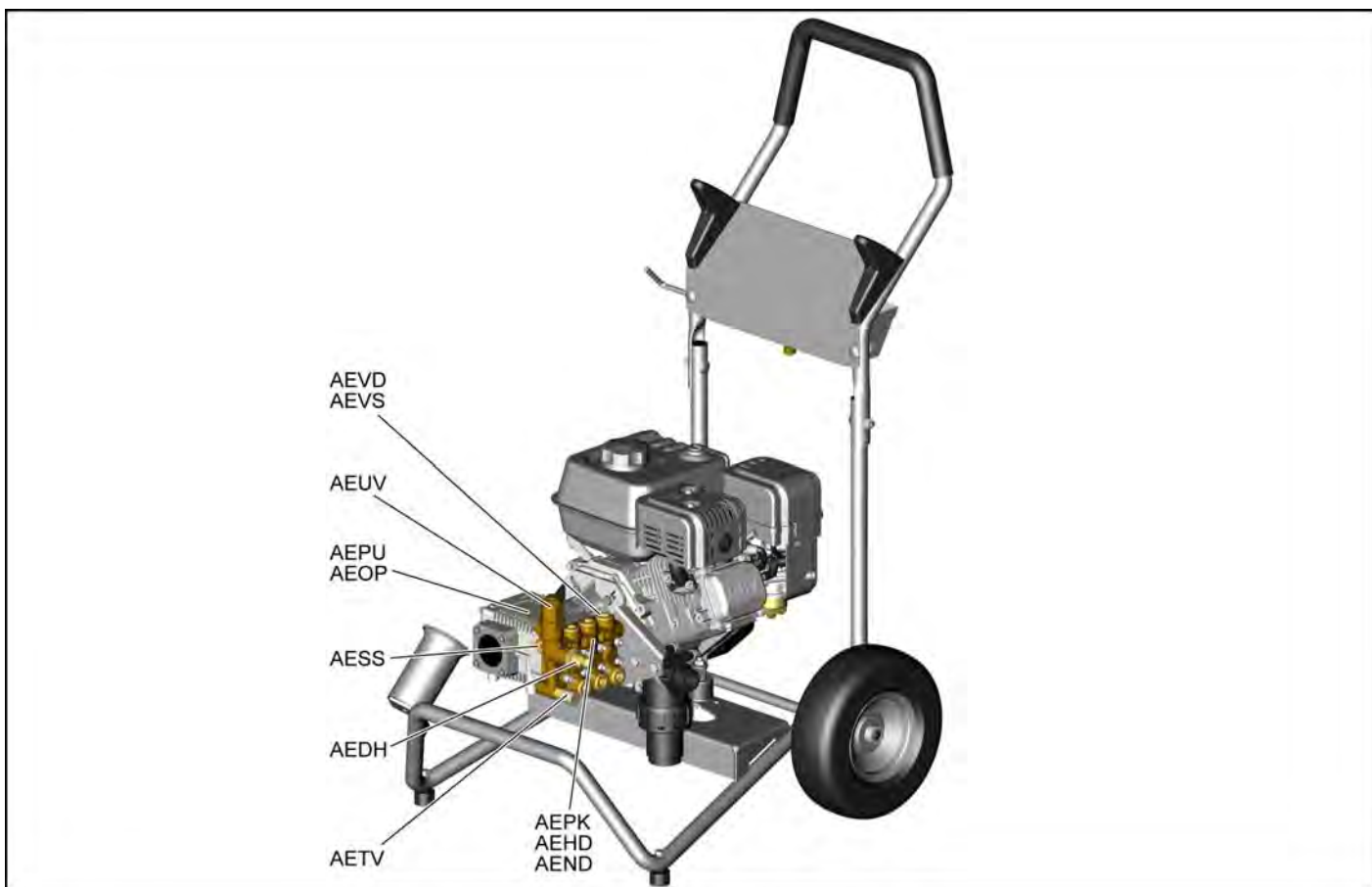

AEVD Uninstalling / installing pressure valves

AEVS Uninstalling / installing suction valves

AEUV Uninstalling / installing the overflow valve

AEPU Uninstalling / installing pump

AEOP Replacing the oil high-pressure pump

AESS Uninstalling / installing safety valve

AEDH Uninstalling / installing pressure retaining valve

AETV Uninstalling / installing the thermostat valve

AEPK Uninstalling / installing pump head

AEHD Uninstalling / installing high-pressure seals

AEND Uninstalling / installing low-pressure seals

### 030 Function

– Overflow valve

When closing the trigger gun, a short pressure surge occurs. This opens the overflow valve and allows water to flow from the delivery side to the suction side of the pump. As long as this pressure surge between the pressure retaining valve and the trigger gun is maintained, the pump runs with circulation pressure. When the trigger gun is opened, the pressure surge is neutralized. The overflow valve closes the connection between the delivery and suction side of the pump again.

– Safety valve

The safety valve opens at the maximum pressure approved for the device. Any further pressure increase is prevented and the line system is protected against overload.

## 040 Service activities

### Note

Unless otherwise described, the installation takes place in reverse order.

### AEUV Uninstalling / installing the overflow valve

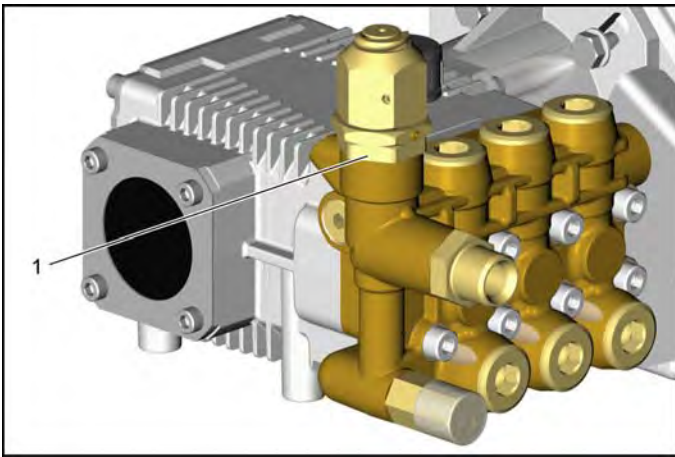

– Pressure holding valve

When releasing the trigger gun, a short pressure surge occurs. The pressure surge is retained between the pressure retaining valve and the trigger gun. In case of leakages in the pump, the permanent switching of the overflow valve is prevented this way.

– Thermostat valve

When excessive water temperatures are reached in the internal circuit of the pump, the valve body opens. Hot water flows to the outside and protects the line system. An integrated spring-loaded ball acts as an air seal in the vacuuming operation and prevents the drawing of air when the valve body is opened.

1 Overflow valve

→ Unscrew the overflow valve.

### Note

Check O-ring for damage.  
Clean the intake and sealing areas.

Torques	Nm
Overflow valve	40...45

## AEUP Checking the overflow valve

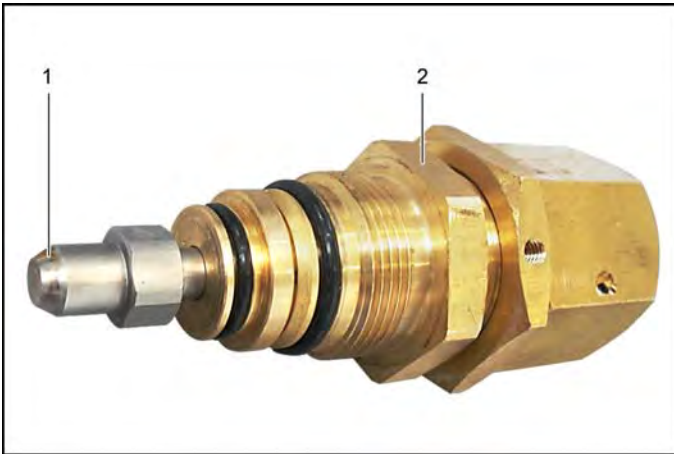

- 1 Cone
- 2 Overflow valve

- Clean overflow valve.
- Check cone for wear.

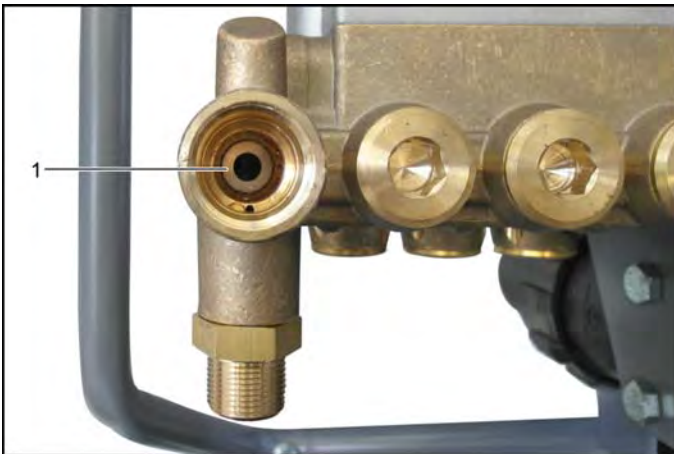

- 1 Valve seat

- Clean valve seat.
- Check valve seat for wear.

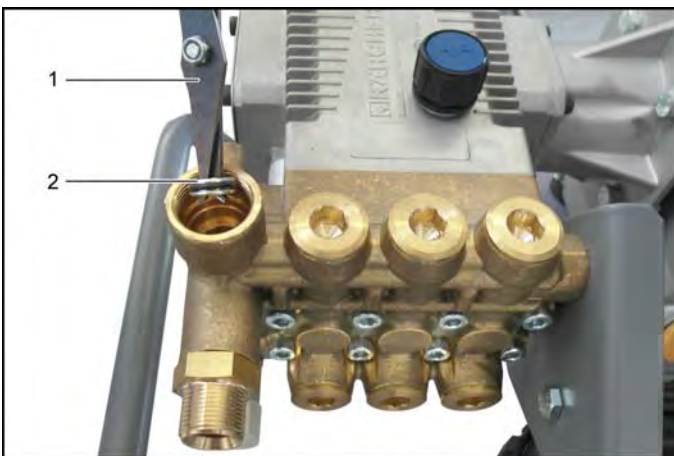

- 1 Valve pliers
- 2 Valve seat

- Dismantle the worn valve seat by means of valve pliers.

## AEUE Adjusting the overflow valve

- Mount the test nozzle on the spray lance.
- Install a pressure gauge between the high-pressure connection and the high-pressure hose.
- Establish the water supply.

### Note

Use special tools.

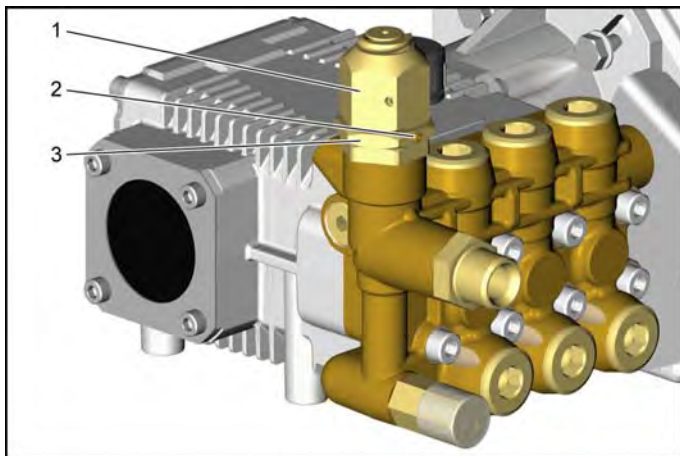

- 1 Rating nut
- 2 Set screw
- 3 Locknut

- Completely screw in the adjustment nut (in a clockwise direction).
- Screw out the threaded pin.
- Loosen the lock nut and turn it all the way down.
- Open the hand spray gun.
- Start the motor.
- Adjust the adjustment nut until the following pressure is displayed:

Device	Opening pressure overflow valve MPa (bar)
HD 6/12 G	13,6...14,0 (136...140)
HD 6/15 G	16,0...16,4 (160...164)
HD 7/20 G	21,2...21,6 (212...216)
HD 8/23 G	22,4...22,8 (224...228)

- Open and close the hand spray gun 3 times while the motor is running.
- Check the set pressure and readjust if necessary.
- Tighten the lock nut against the adjustment nut without moving it.
- Screw in the threaded pin and tighten it.
- Reinstall the original power nozzle on the spray lance.
- Start the motor.
- Open the hand spray gun.
- Working pressure is applied.  
Refer to chapter "Technical data".
- Open and close the hand spray gun 3 times while the motor is running.
- Seal the adjustment nut and lock nut by means of locking paint.

## AESS Uninstalling / installing safety valve

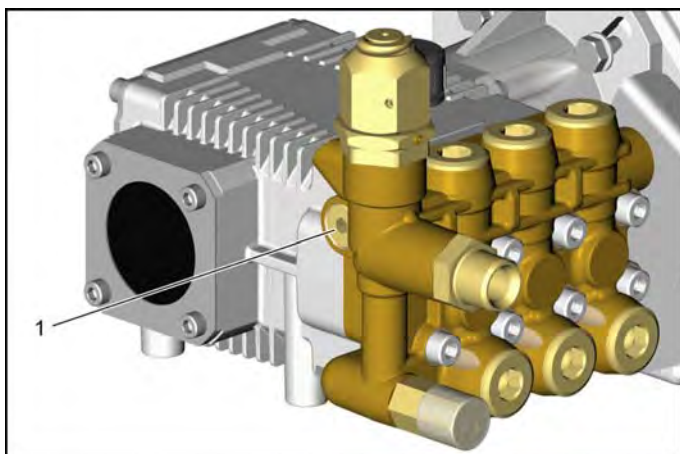

- 1 Safety valve

- Unscrew the safety valve.

### Note

Check O-ring for damage.  
Clean the intake and sealing areas.

## AESP Checking the safety valve

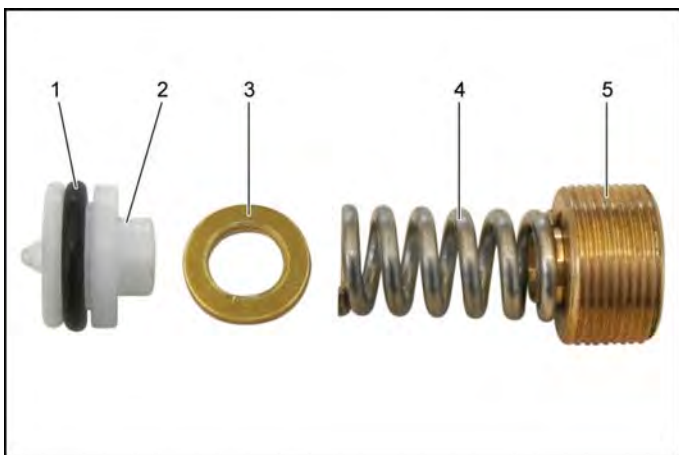

- 1 O ring
- 2 Valve body
- 3 Washer
- 4 Spring
- 5 Adjustment screw

- Check the valve body, washer, spring and O-ring.
- Check the valve seat in the cylinder head.
- Replace defect parts
- Reassemble the valve.

## AESE Adjusting the safety valve

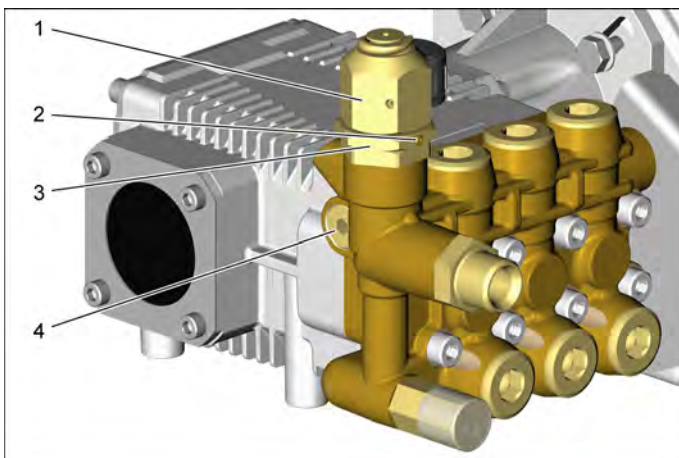

- 1 Rating nut
- 2 Set screw
- 3 Locknut
- 4 Safety valve
- 5 Adjustment screw, safety valve

- Turn off the appliance.
- Install test manometer for working pressure and stop valve with thermometer between pressure retaining valve and high-pressure line.
- Mark the setting of the overflow valve.
- Open water inlet and trigger gun.
- Screw the adjustment screw of the safety valve 2.5 mm in.

Distance (a)	mm
Between front edge pump head and adjustment screw safety valve	2,5

- Start the motor.
- Loosen the threaded pin on the lock nut.
- Loosen the locknut.
- Screw the adjustment nut onto the block.
- Reduce the water flow in the high-pressure line by means of the stop valve until the opening pressure of the safety valve is reached.

Device	Opening pressure safety valve MPa (bar)
HD 6/12 G	17 (170)
HD 6/15 G	20 (200)
HD 7/20 G	25 (250)
HD 8/23 G	28 (280)

- Slowly unscrew the safety valve until the first drops leak from the opening of the safety valve.
- Turn off the appliance.
- Close trigger gun and water inlet.
- Open stop valve in the high-pressure line.
- Seal the safety valve with locking paint.
- Set the overflow valve to the previously marked position.
- Perform adjustment of the overflow valve.

### Installation information

- *AEUE Adjusting the overflow valve*

### Note

Use special tools.

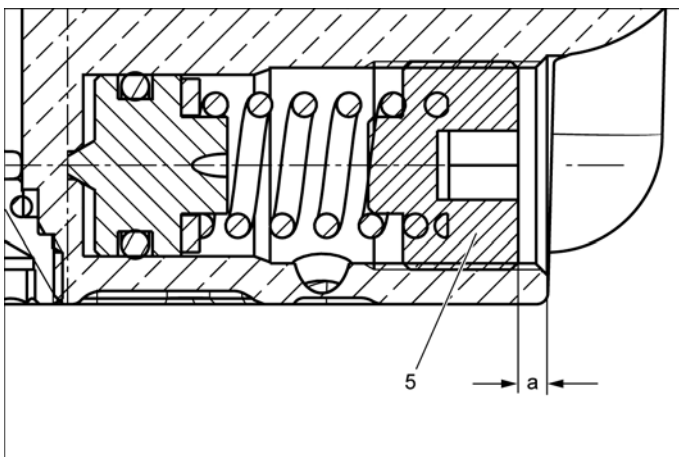

## AEDH Uninstalling / installing pressure retaining valve

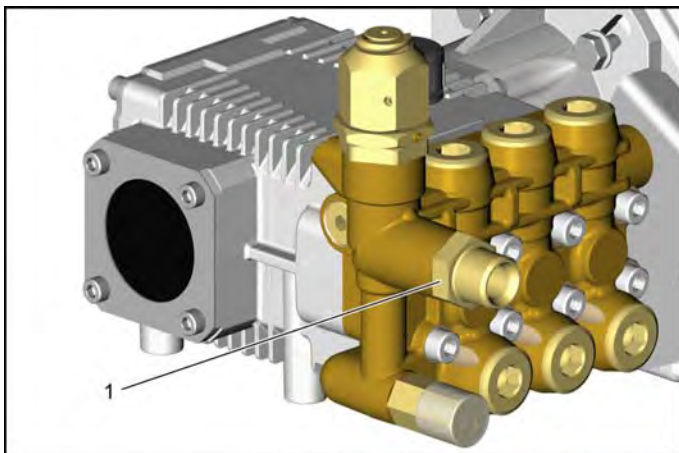

1 Pressure holding valve

→ Unscrew the pressure retaining valve.

### Note

Check O-ring for damage.  
Clean the intake and sealing areas.

Torques	Nm
Pressure holding valve	40...45

## AEDP Checking the pressure retaining valve

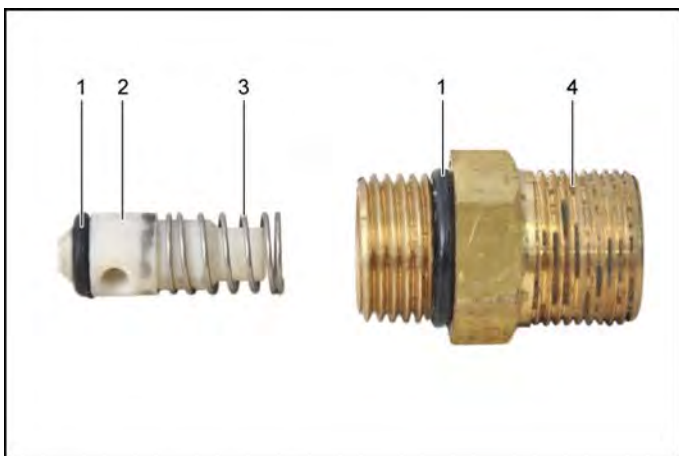

1 O rings  
2 Valve body  
3 Spring  
4 Branch

→ Check the valve body, spring and O-ring.  
→ Check the valve seat in the cylinder head.  
→ Replace defect parts  
→ Reassemble the valve.

## AETV Uninstalling / installing the thermostat valve

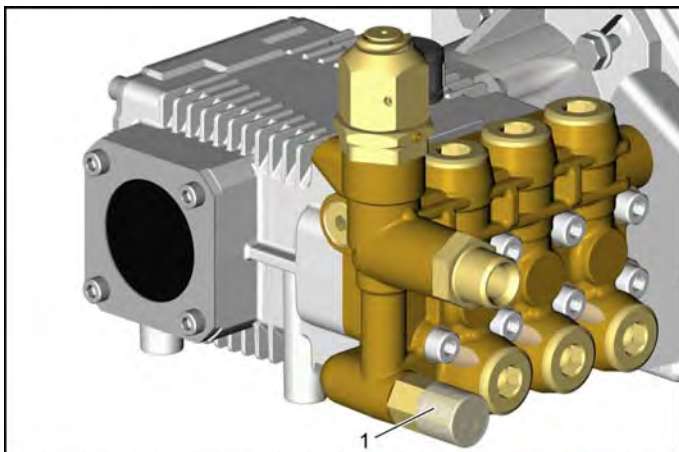

1 Thermostat valve

→ Unscrew the thermostat valve.

### Note

Check O-ring for damage.  
Clean the intake and sealing areas.

Torques	Nm
Thermostat valve	15...17

## AETP Checking the thermostat valve

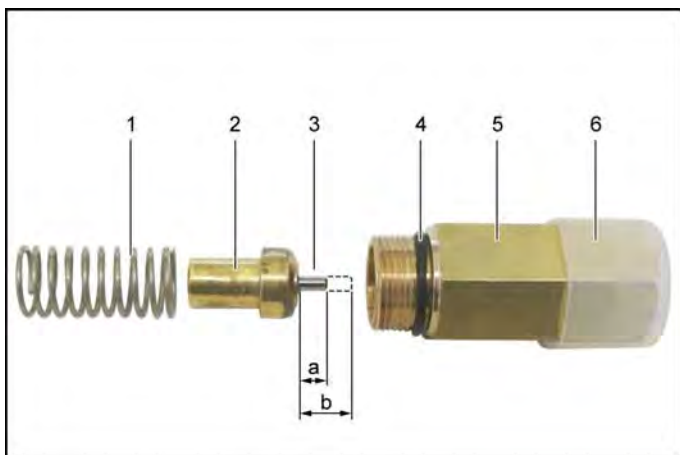

- 1 Spring
- 2 Valve body
- 3 Pin
- 4 O ring
- 5 Branch
- 6 Cover

- ➔ Check the valve body, spring and O-ring.
- ➔ Replace defect parts
- ➔ Reassemble the valve.

### Note

Linear expansion of the pin at different temperature.  
 Pin length (a) 6 mm at 20 °C.  
 Pin length (b) 9.5 mm at 83...95 °C.

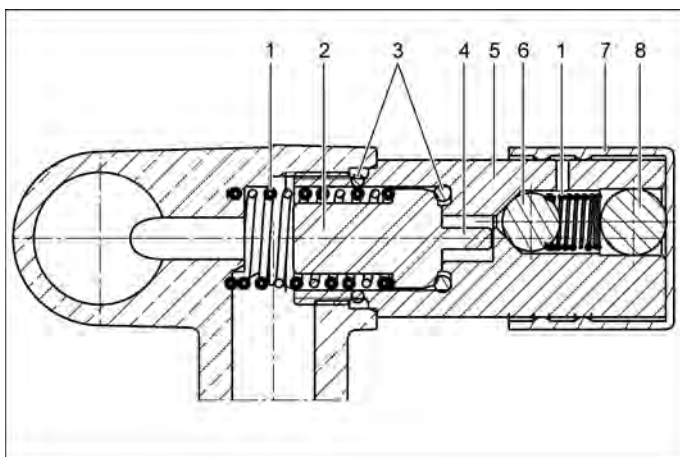

### Sectional drawing thermostat valve

- 1 Spring
- 2 Valve body
- 3 O ring
- 4 Pin
- 5 Branch
- 6 Air seal
- 7 Cover
- 8 Stopper

## AEPK Uninstalling / installing pump head

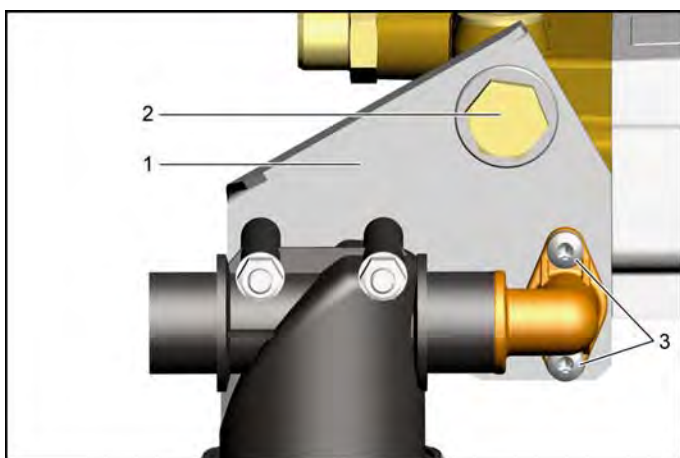

- AEHD Uninstalling / installing high-pressure seals
- AEUV Uninstalling / installing the overflow valve
- AEDH Uninstalling / installing pressure retaining valve
- AETV Uninstalling / installing the thermostat valve
- AESS Uninstalling / installing safety valve
- AEVD Uninstalling / installing pressure valves
- AEVS Uninstalling / installing suction valves

- 1 Halting plate
- 2 Screw plug
- 3 Screws

- ➔ Unscrew the screws.
- ➔ Remove holding plate with water filter.

Torques	Nm
Screw	9...11
Screw plug	40...45



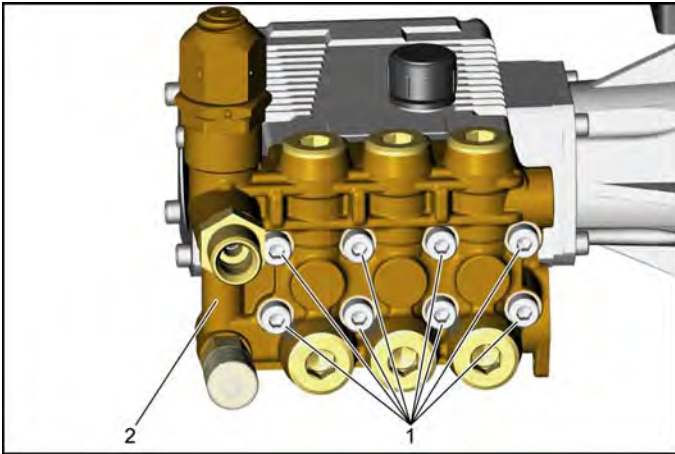

- 1 Screws
- 2 Pump head

- Unscrew the screws.
- Remove the pump head.

Torques	Nm
Screws pump head	20...25

### AEPU Uninstalling / installing pump

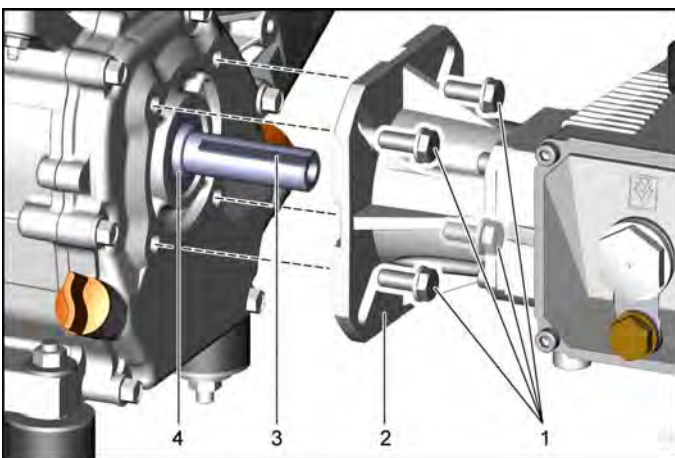

- *AEPK Uninstalling / installing pump head*  
If required

- 1 Screws
- 2 Pump
- 3 Fitting key
- 4 Seal

- Unscrew the screws.
- Remove pump.

Torques	Nm
Screws	20...25

Grease shaft / hub	6.869-088.0
--------------------	-------------

### AEVD Uninstalling / installing pressure valves

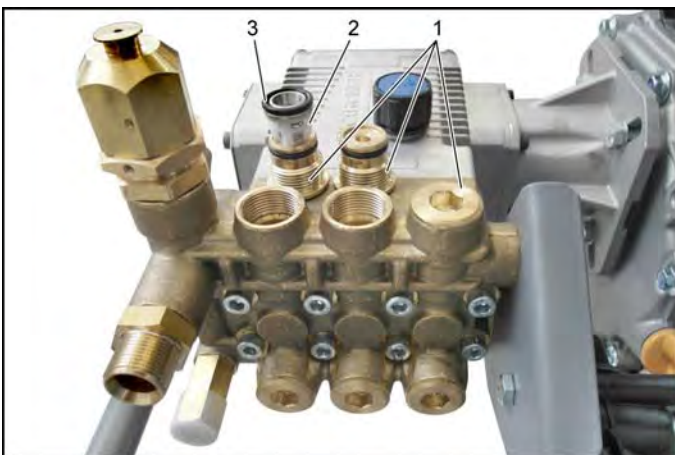

- 1 Valve screws pressure valve
- 2 Valve
- 3 O ring

- Unscrew the valve screws.
- Remove valve and O-ring.
- Insert a new O-ring in the drilled hole.
- Insert a new valve.
- Check the O-ring of the valve screw, replace if necessary.
- Insert and tighten valve screw.

Torques	Nm
Valve screws pressure valve	40...45

## AEVS Uninstalling / installing suction valves

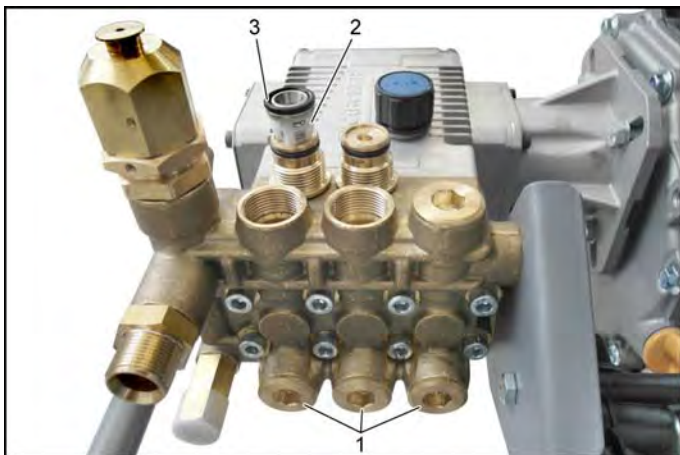

- 1 Valve screws suction valve
- 2 Valve
- 3 O ring

- ➔ Unscrew the valve screws.
- ➔ Remove valve and O-ring.
- ➔ Insert a new O-ring in the drilled hole.
- ➔ Insert a new valve.
- ➔ Check the O-ring of the valve screw, replace if necessary.
- ➔ Insert and tighten valve screw.

Torques	Nm
Valve screws suction valve	40...45

## AEND Uninstalling / installing low-pressure seals

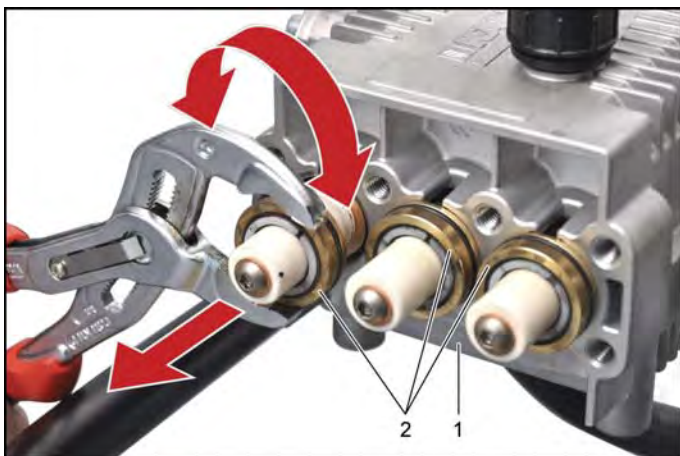

### ■ AEPK Uninstalling / installing pump head

#### Note

Always renew all high-pressure and low-pressure seals together.

- 1 Crankcase
- 2 Low-pressure seal packages

- ➔ Turn the low-pressure seal packages back and forth and pull them off the ceramic piston at the same time.
- ➔ Clean the ceramic piston and check for cracks.
- ➔ If there is oil on the piston side of the crankshaft casing, the oil seals must be replaced.

### ■ AEOD Uninstalling / installing oil seals



Low-pressure seal package, consisting of:

- 1 O ring
- 2 Brass sleeve
- 3 Disc
- 4 Washer ring
- 5 Spreader ring

- ➔ Assemble new low-pressure sealing packages. Reuse the brass sleeves when doing so.
- ➔ Slightly grease the inside of the sealing rings.
- ➔ Lightly grease the O-rings.
- ➔ Push the low pressure gasket packages onto the ceramic sleeves of the piston.

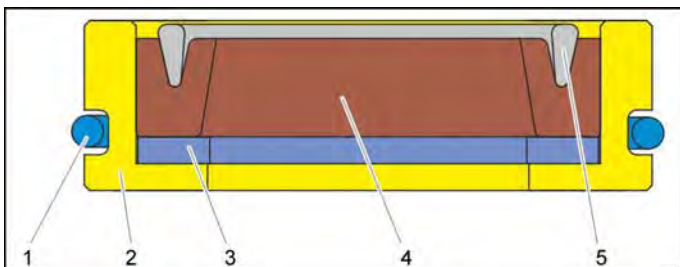

Grease	6.288-079.0
--------	-------------

## AEHD Uninstalling / installing high-pressure seals

### ■ AEPK Uninstalling / installing pump head

#### Note

Always renew all high-pressure and low-pressure seals together.

- 1 Cylinder head
- 2 High-pressure seal packages

→ Dismantle the high pressure gasket packages by means of valve pliers.

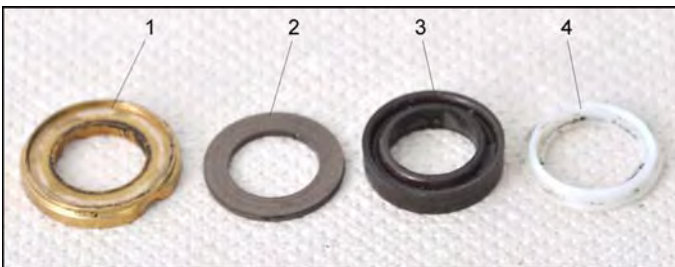
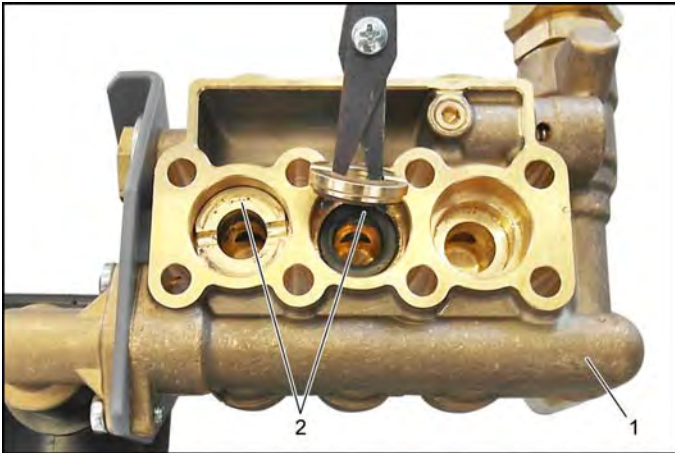

High-pressure seal package, consisting of:

- 1 Brass disc
- 2 Disc
- 3 Washer ring
- 4 Spreader ring



- 1 Spreader ring
- 2 Cylinder head

→ Insert the spreader ring in the drilled hole of the cylinder head.

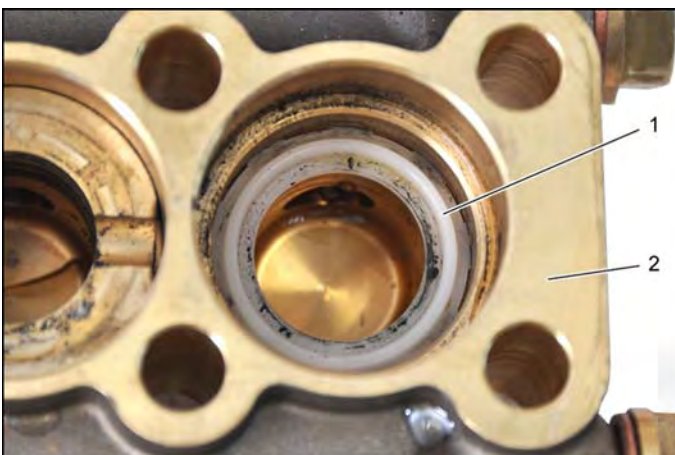

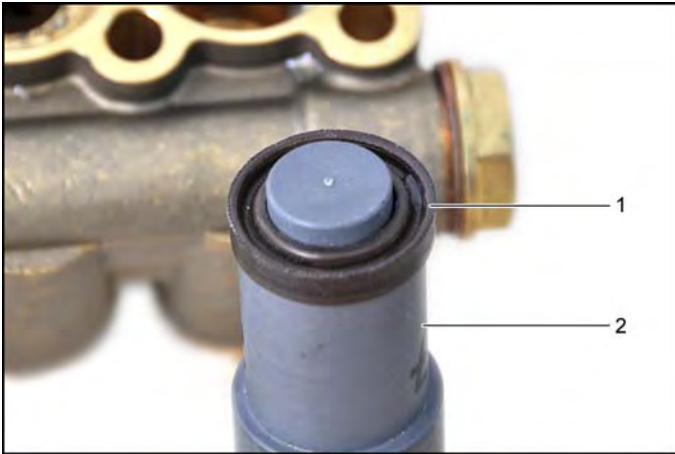

- 1 Washer ring
- 2 Installation mandrel

➔ Push the sealing ring onto the installation mandrel.

**Note**

Use special tools.

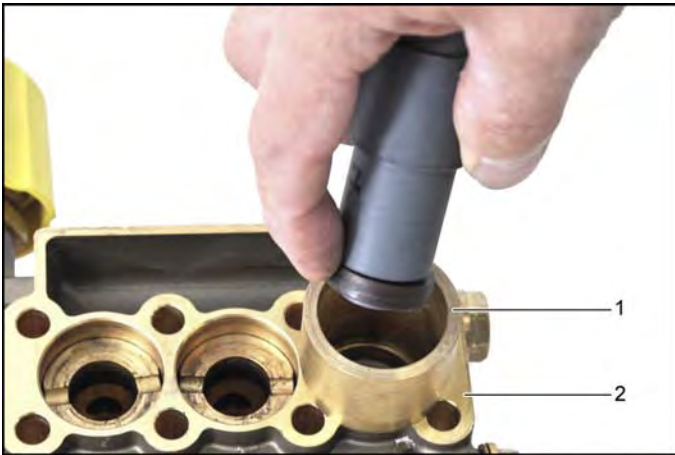

- 1 Installation sleeve
- 2 Cylinder head

- ➔ Place the installation sleeve on the cylinder head.
- ➔ Push the sealing ring through the installation sleeve into the cylinder head using the installation mandrel.
- ➔ Slightly grease the inside of the sealing ring.

**Note**

Use special tools.

Grease	6.288-079.0
--------	-------------



- 1 Disc
- 2 Brass disc

➔ Place the disc inside the brass disc.

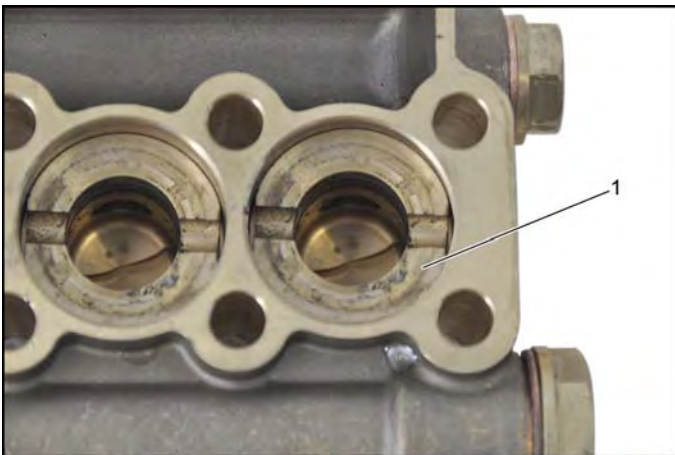

- 1 Brass disc with washer

➔ Insert both discs of the high pressure gasket package in the cylinder head together.

## AEKK Uninstalling / installing ceramic piston

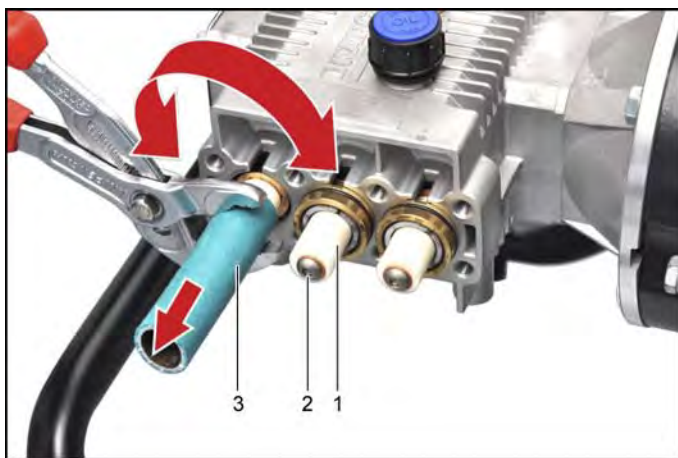

- AEPK Uninstalling / installing pump head
- AEND Uninstalling / installing low-pressure seals

- 1 Low-pressure seal package
- 2 Ceramic piston
- 3 Screw

→ Loosen screws.

- 1 Ceramic piston
- 2 Screw
- 3 Hose section

→ Pull off ceramic piston.

→ Attach new ceramic piston.

→ Apply soluble screw securing adhesive to the screw or use a new screw with securing coating.

→ Screw in the screws and tighten them.

### ⚠ CAUTION

*Risk of damage. Do not directly touch the ceramic piston with pliers. If a tool is required for removal, use a piece of hose for protection.*

Torques	Nm
Screw	9...11

## AEOD Uninstalling / installing oil seals

### Draining the oil

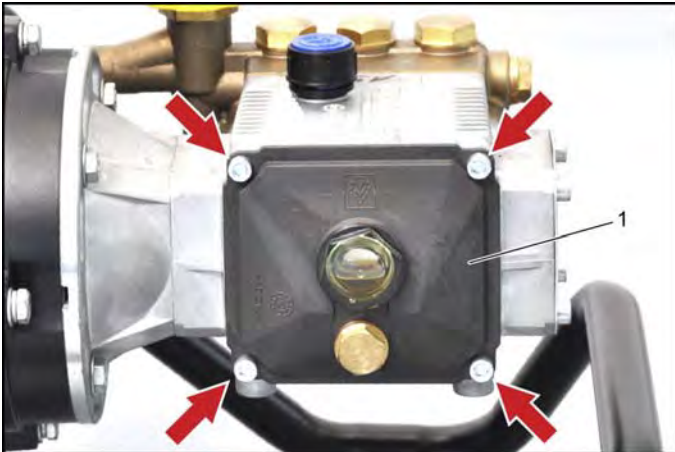

### Removing the ceramic piston

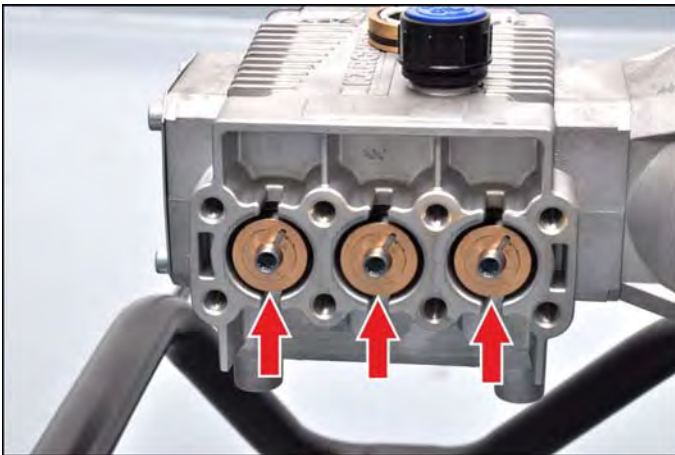

### Dismantling the drive

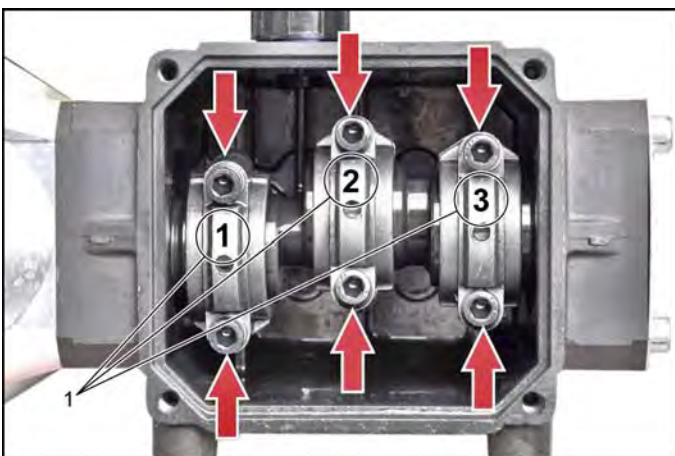

### ■ AEPK Uninstalling / installing pump head

#### 1 Cover

- Place an oilpan underneath the pump.
- Unscrew the screws.
- Remove the lid.
- Drain and collect the oil.

#### Note

If chips of destroyed pump components are visible in the crankshaft casing or in the oil, the pump is damaged and a repair no longer reasonable. In this case, replace the entire crank drive.

### ■ AEKK Uninstalling / installing ceramic piston

### ■ AEPU Uninstalling / installing pump

- Remove copper discs.

#### 1 Identification

- Mark the bearing shells (in the example: 1, 2, 3).
- Unscrew the screws.

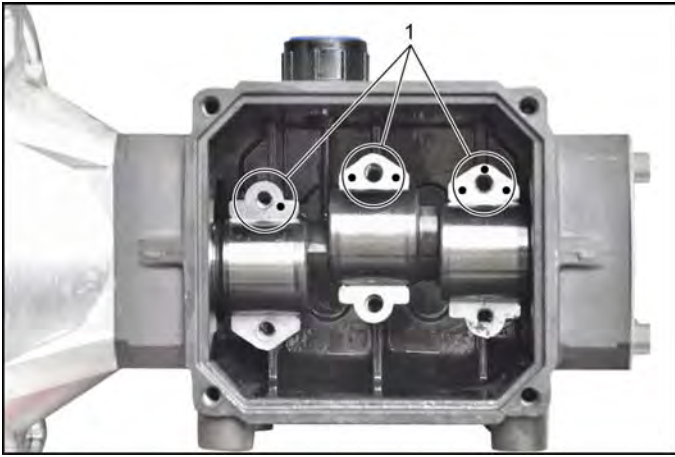

1 Identification

- ➔ Remove the bearing shells.
- ➔ Mark the piston rods (in the example: 1 dot, 2 dots, 3 dots).

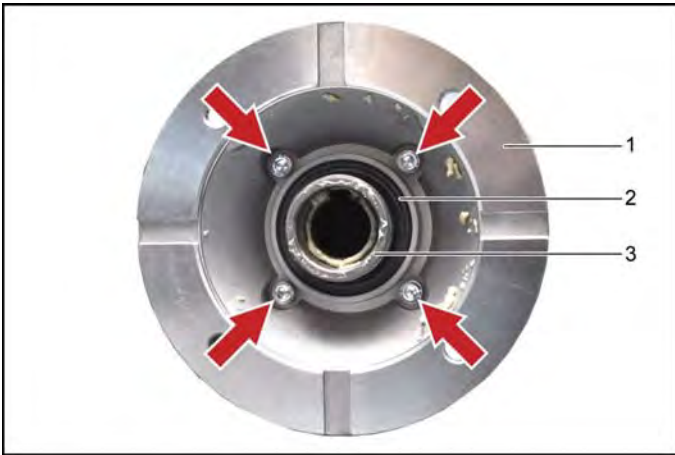

- 1 Flange
- 2 Shaft seal ring
- 3 Crankshaft pump

- ➔ Unscrew the screws.
- ➔ Pull the flange off the crankshaft casing.

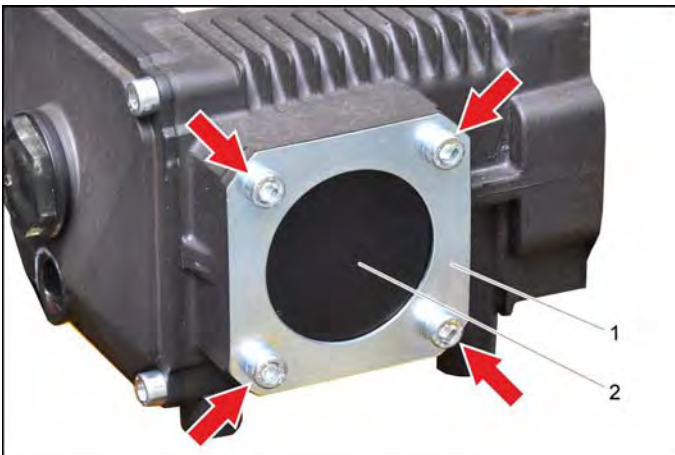

- 1 Cover
- 2 Bearing cover

- ➔ Unscrew the screws.
- ➔ Remove the lid.

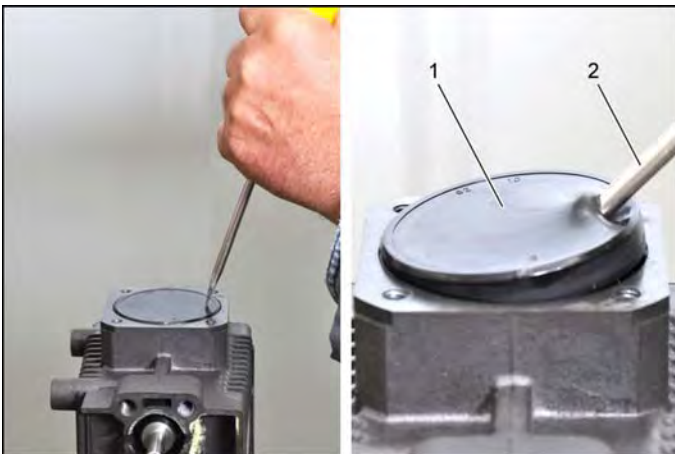

- 1 Cover
- 2 Screwdriver

- ➔ Drive the screwdriver into the cover and prise the cover open.

**⚠ CAUTION**

*Risk of damage for the subjacent ball bearing and the gasket seat in the crankshaft casing. Do not position the screwdriver to close to the edge of the cover.*

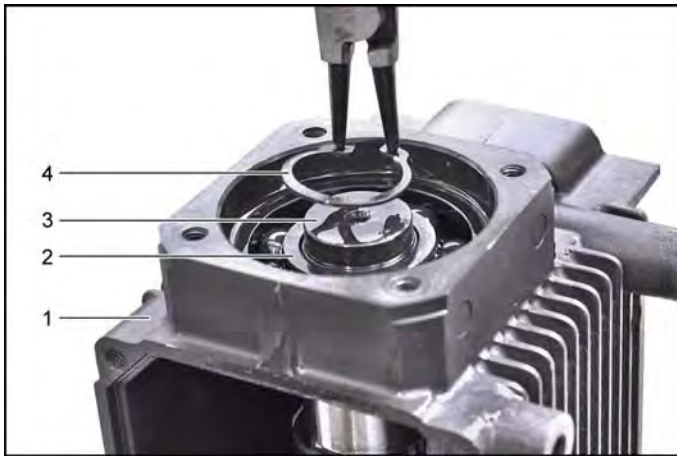

- 1 Crankcase
- 2 Bearings
- 3 Crankshaft
- 4 Safety ring

- ➔ Remove the safety ring from the shaft.
- ➔ Push all pistons completely towards the cylinder head.

### Dismantling the crankshaft

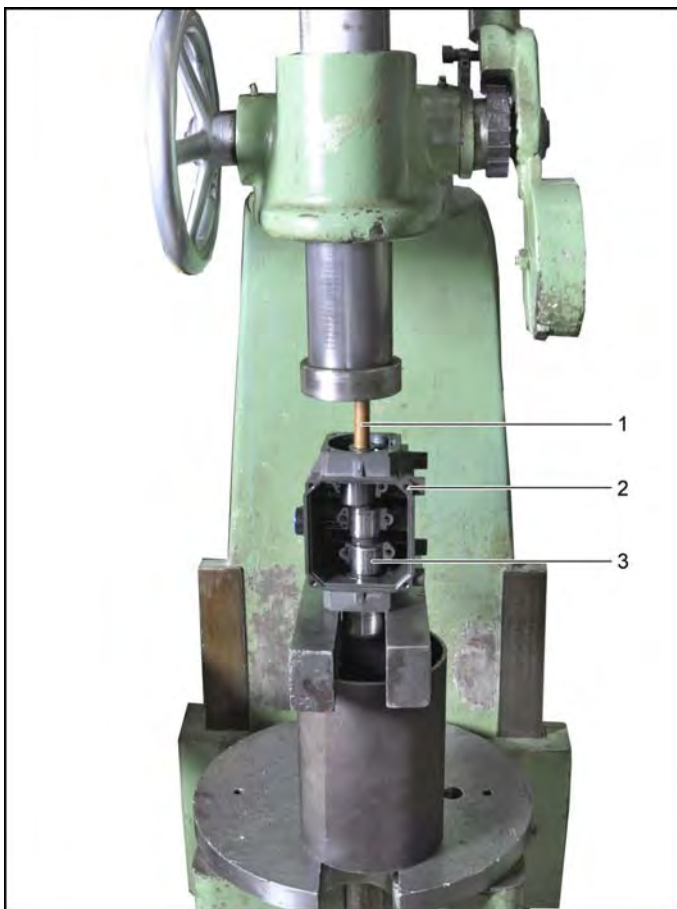

- 1 Pressing mandrel
- 2 Crankcase
- 3 Crankshaft

- ➔ Squeeze out the crankshaft in small steps. Between every step, ensure that the piston rods are not jammed or damaged by the crankshaft.
- ➔ Turn crankcase by 180°.



- 1 Pipe section
- 2 Crankcase

- ➔ Insert a suitable pipe section, e.g. 50x2x250 mm.
- ➔ Squeeze out the ball bearing and dispose of.





- 1 Pipe section
- 2 Bearings

- ➔ Press a new ball bearing into the crankshaft casing.
- ➔ Pull the piston rod with the piston out of the crankshaft casing.

**⚠ CAUTION**

*Risk of damage for the ball bearing. Choose the diameter of the pipe section so that the press-in force acts on the outer ring of the ball bearing.*

**Dismantling the oil seals**



- ➔ Push the oil seal out of the crankshaft casing from the inside to the outside.

**⚠ CAUTION**

*Risk of damage for the gasket seat. Carefully use a screwdriver when dismantling the gasket.*

or



- ➔ Lever out the outer oil seal from the cylinder head side.
- ➔ Clean and check the gasket seat.



- 1 Installation spot in the crankcase (free of oil and grease)
- 2 Installation mandrel
- 3 Oil seal

- ➔ Place the oil seal on the installation mandrel and moisten with water. Do not use oil or grease.

**Note**

Use special tools.

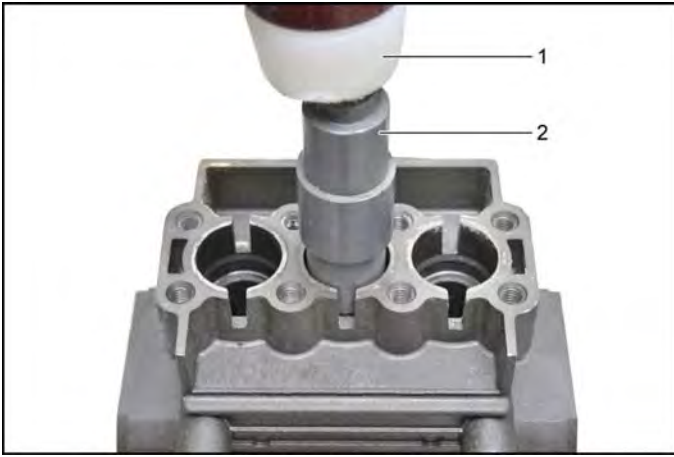

**Installing the crankshaft**

- 1 Plastic hammer
- 2 Installation mandrel

- ➔ Drive the oil seal into the drilled hole by means of the installation mandrel.
- ➔ Lightly lubricate the piston and piston rod bearing.
- ➔ Insert the piston into the crankshaft casing and completely push towards the cylinder head.
- ➔ Check the running surface of the crankshaft casing (2x bearing positions, 3x piston rods).

**Note**

Pay attention to the correct fitting position during reinstallation.

- ➔ Insert the crankshaft in the crankcase and press it into the new ball bearing in small steps. Between every step, ensure that the piston rods are not jammed or damaged by the crankshaft.

**⚠ CAUTION**

*Risk of damage for the ball bearing. When pressing the crankshaft in, support the ball bearing at the inner and outer ring.*

**Disassembling and assembling the shaft seal**

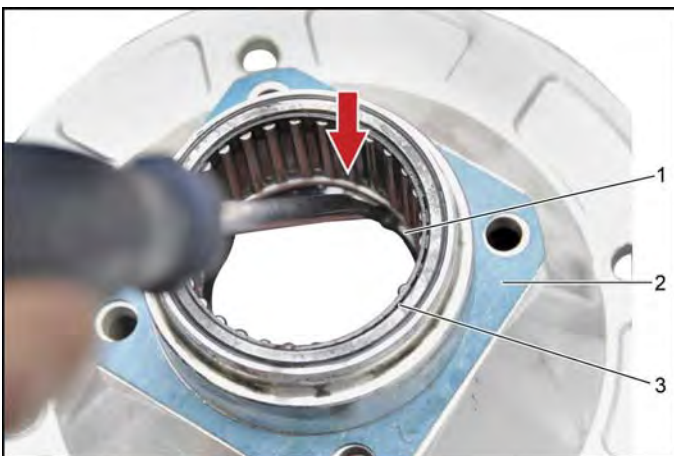

**Replace needle bearing (if necessary):**

- 1 Shaft seal ring
- 2 Flange
- 3 Needle bearing

- ➔ Heat the flange - the needle bearing will fall out.
- ➔ Press new needle bearing all the way in.



- 1 Flange
- 2 Pipe section

- ➔ Push the shaft seal ring out of the flange.
- ➔ Clean and check the gasket seat.
- ➔ Moisten the new sealing ring with water and press it in.

**⚠ CAUTION**

*Risk of damage for the gasket seat. Carefully use a screwdriver when dismantling the gasket.*



1 O ring

- ➔ Replace O-ring.
- ➔ Attach the flange on the crankshaft casing.
- ➔ Mount the retaining ring to the crankshaft.

Torques	Nm
Flange on crankcase	17

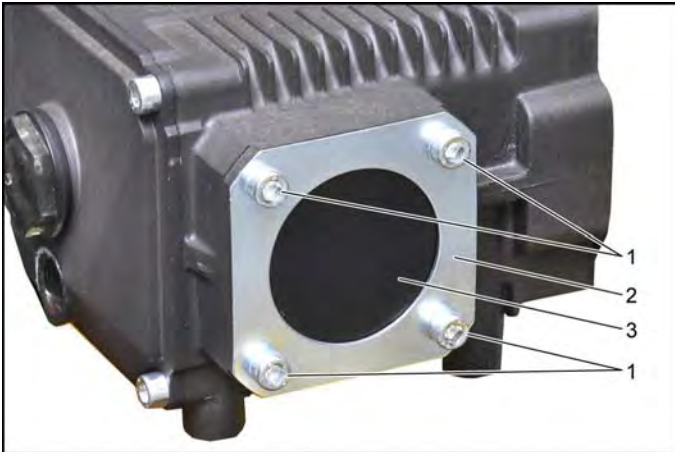

1 Screws  
2 Cover  
3 Cover

- ➔ Lightly grease the new cover and press it in.
- ➔ Mount the lid.
- ➔ Tighten the screws.

Torques	Nm
Screws	9...11



1 Bearing cup  
2 Screws

- ➔ Install the bearing shells of the piston rods, observe marking.  
Apply soluble screw securing adhesive to the screws and tighten them.
- ➔ Attach the lid to the crankshaft casing.
- ➔ Grease the shaft in the area of the feather key.
- ➔ Attach the pump to the motor.  
Observe the axial alignment and do not distort parts.  
Tighten screws in a criss-cross pattern.
- ➔ Install the cylinder head.
- ➔ Refill fresh oil.  
The oil level is checked at the sight gauge, the level should be at least up to the middle of the sight gauge.

Torques	Nm
Bearing shell on connecting rod	12...14
Cover on crankcase	9...11
Pump at motor	20...25
Cylinder head on crankcase	20...25
Flange on crankcase	17
Grease shaft / hub	6.869-088

## 050 Maintenance and inspection

### AEOP Replacing the oil high-pressure pump

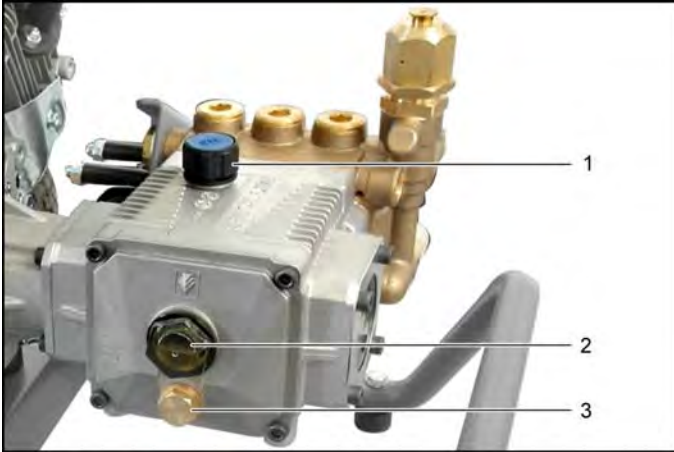

- 1 Oil fill screw
- 2 Oil level indicator
- 3 Oil drain screw

- Unscrew oil drain plug.
- Drain the oil in a collection basin.
- Fix in the oil drain screw and tighten it.
- Turn the oil fill screw out.
- Fill in new oil slowly; air bubbles should go out.  
The oil level must be at the centre of the oil level display.
- Screw in oil filling screw.

Torques	Nm
Oil drain screw	20...25

## 060 Error diagnosis

Fault	Cause	Correction
Appliance is not building up pressure		Set the pressure and quantity regulation to "MAX".
		Check the nozzle size, install correct nozzle.
		Clean the nozzle.
		Replace the nozzle.
		Check water supply level (refer to technical data).
		Clean water filter.
		Check all inlet pipes to the pump.
Check the settings of the transfer port.		
Water is leaking at the pump	3 drops per minute are permitted and can come out from the lower side of the appliance.	Replace high and low pressure gaskets.
Oil is leaking at the pump		Replace the oil seals.
		Insert shaft seals.
Pump is vibrating		Clean water filter.
		Check the water suction pipes for leaks.
When the trigger gun is closed the device runs irregularly		Check the pump for leaks.
		Check the high-pressure hose and the hand spray gun for leaks.
		Check the pressure retaining valve.

## 070 Peculiarities/ others

The service group does not contain any peculiarities.

## 010 Safety information

### General

Observe general safety information!

Service and maintenance tasks may only be performed by qualified and specially trained specialists.

#### **⚠ DANGER**

- *Switch off the appliance and, in case of appliances connected to the mains, pull out the power cord before cleaning and performing any maintenance tasks on the machine.*
- *Relieve the high pressure system of all pressure prior to all work on the appliance and the accessories.*
- *Maintenance work may only be carried out by approved customer service outlets or experts in this field who are familiar with the respective safety regulations.*
- *To avoid risks, all repairs and replacement of spare parts may only be carried out by the authorised customer service personnel.*
- *Only use accessories and spare parts which have been approved by the manufacturer. The exclusive use of original accessories and original spare parts ensures that the appliance can be operated safely and trouble free.*
- *Only use the fuels specified in the Operations Manual. Risk of explosion due to the use of inappropriate fuels.*
- *In petrol engine appliances, ensure that no petrol comes in contact with hot surfaces.*
- *Ensure that there is adequate ventilation or provision for diverting the exhaust gas while operating the appliance in closed rooms (risk of poisoning).*
- *Do not close the exhaust.*
- *Please ensure that there are no exhaust emissions near the air inlets.*
- *Do not use high pressure cleaners when there has been an oil spill; move the appliance to another spot and avoid any sort of spark formation.*
- *Do not store, spill or use fuel in the vicinity of open flames or appliances such as ovens, boilers, water heaters, etc. that have an ignition flame or can generate sparks.*
- *Do not use unsuitable fuels, as they may be dangerous.*
- *Keep even mildly inflammable objects and materials away from the muffler (at least 2 m).*
- *Do not start the engine without the muffler; check, clean and replace, if required, the muffler at regular intervals.*
- *Except for setting jobs, do not run the engine when the air filter is removed or there is no cover over the suction support.*
- *Risk of burns! Do not touch hot mufflers, cylinders or radiator ribs.*
- *Do not put hands or feet close to moving or rotating parts.*
- *Risk of poisoning! The appliance should not be operated in closed rooms.*

#### **⚠ WARNING**

- *Do not bend over the exhaust or touch it.*

## 020 Overview

### Internal combustion engine

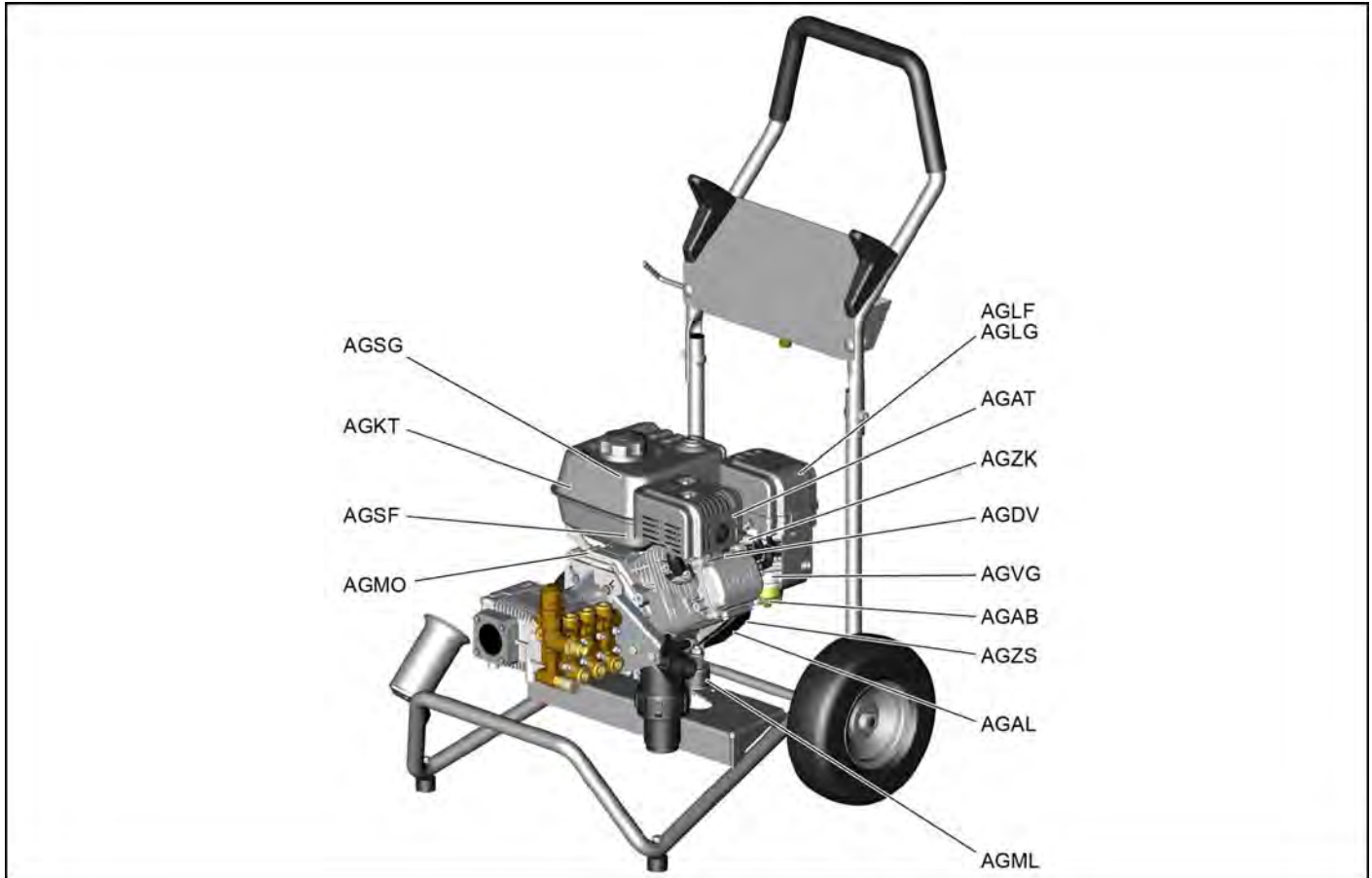

*AGSG Uninstalling / installing coarse sieve fuel tank*

*AGKT Uninstalling / installing fuel tank*

*AGSF Uninstalling / installing fine sieve fuel tank*

*AGMO Changing the engine oil*

*AGLF Uninstalling / installing air filter*

*AGLG Uninstalling / installing casing of the air filter*

*AGAT Uninstalling / installing muffler*

*AGZK Uninstalling / installing spark plug*

*AGDV Uninstalling / installing seal valve cover*

*AGVG Uninstalling / installing carburettor*

*AGAB Uninstalling / installing sediment cup*

*AGZS Uninstalling / installing ignition coil*

*AGAL Uninstalling / installing cover fan wheel*

*AGML Uninstalling / installing engine mount*

## 040 Service activities

### Note

Unless otherwise described, the installation takes place in reverse order.

### AGAB Uninstalling / installing sediment cup

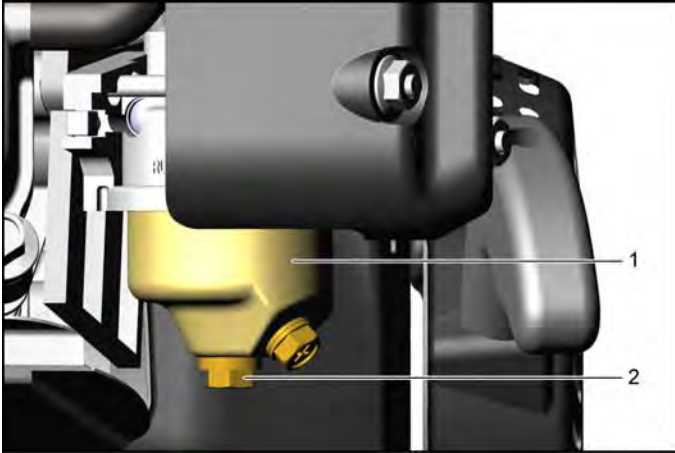

- 1 Sediment cup
- 2 Screw

- ➔ Close fuel cock.
- ➔ Loosen the screw.
- ➔ Remove sediment cup.

### Note

Check O-ring for damage.  
Clean the intake and sealing areas.

### AGAL Uninstalling /installing cover fan wheel

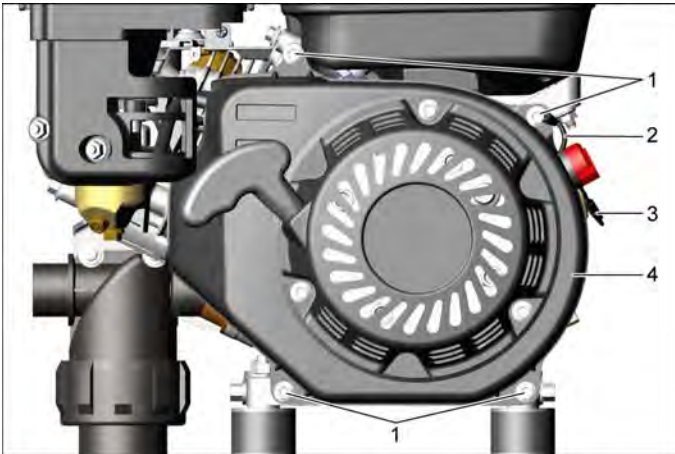

- 1 Screws
- 2 Ground cable
- 3 Socket plug connection
- 4 Cover of fan wheel

- ➔ Disconnect the connector.
- ➔ Unscrew the screws.
- ➔ Remove earth cable.
- ➔ Remove the cover of the fan wheel.

### AGAT Uninstalling / installing muffler

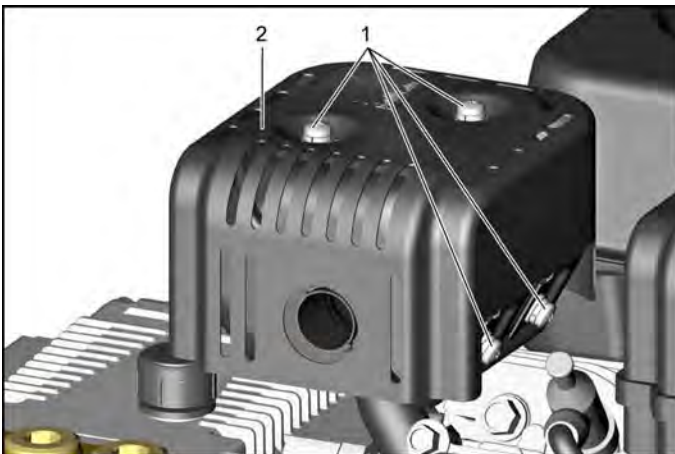

- 1 Screws
- 2 Cover

- ➔ Unscrew the screws.
- ➔ Remove cover.

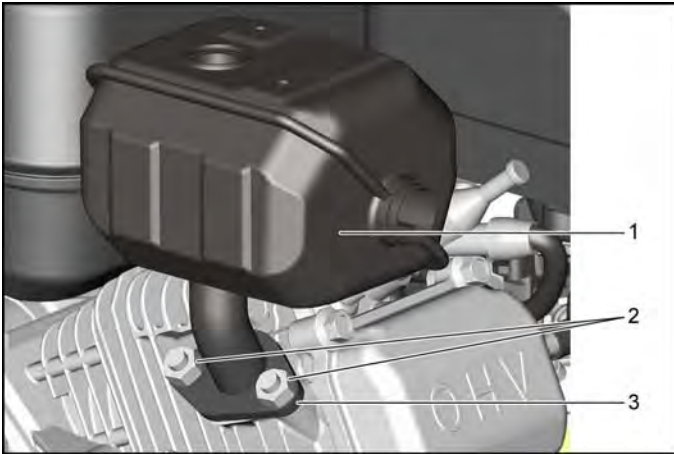

- 1 Muffer
- 2 Nuts
- 3 Seal

- ➔ Loosen the mounting nuts.
- ➔ Remove muffer.

**Note**

Check the gasket for damage.

**AGDV Uninstalling / installing seal valve cover**

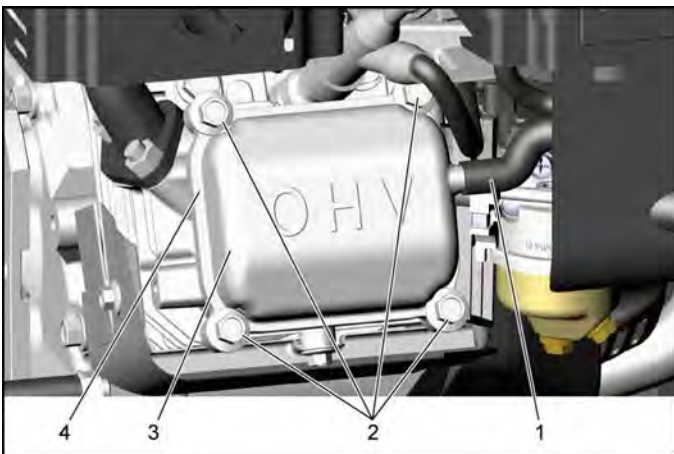

- 1 Hose
- 2 Screws
- 3 Valve cover
- 4 Seal valve cover

- ➔ Pull out the hose.
- ➔ Unscrew the screws.
- ➔ Remove the valve cover.
- ➔ Remove the seal of the valve cover.

**Note**

Clean the intake and sealing areas.

**AGKT Uninstalling / installing fuel tank**



- 1 Hose
- 2 Screw
- 3 Ignition plug

- ➔ Pull out the hose.
- ➔ Remove spark-plug connector.
- ➔ Loosen the screw.

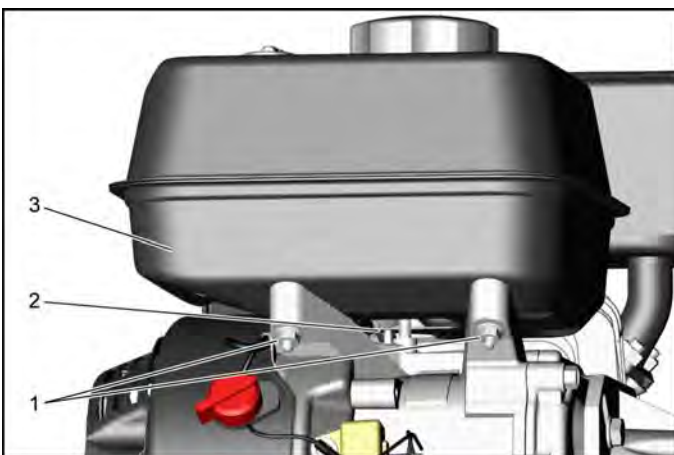

- 1 Nuts
- 2 Hose
- 3 Fuel tank

- ➔ Loosen the mounting nuts.
- ➔ Pull out the hose.
- ➔ Remove fuel tank.

**Note**

After removal of the hose, fuel may leak.



## AGLF Uninstalling / installing air filter

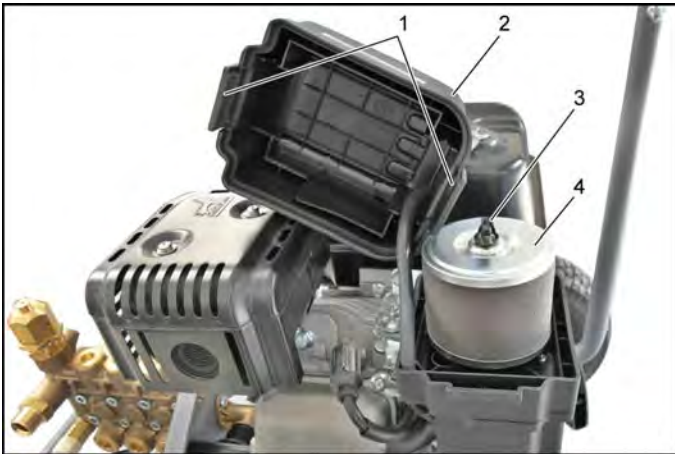

- 1 Locking
- 2 Cover air filter
- 3 Wing nut
- 4 Air filter

- Open the lock.
- Remove cover of the air filter.
- Unscrew wing nut.
- Change the air filter.

## AGLG Uninstalling / installing casing of the air filter

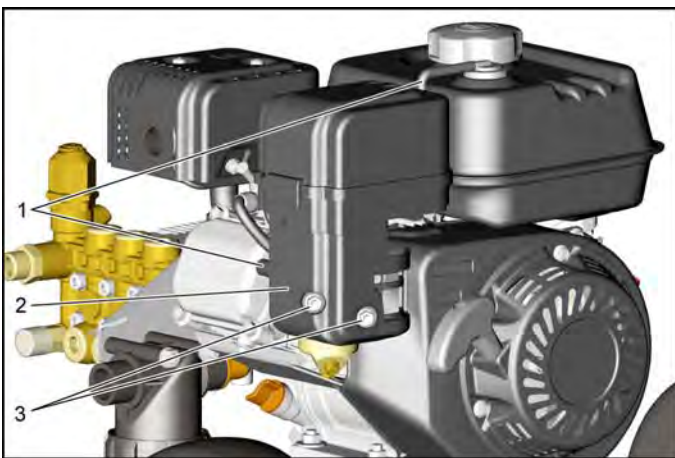

### ■ AGLF Uninstalling / installing air filter

- 1 Hose
- 2 Casing air filter
- 3 Nuts

- Pull out the hose.
- Loosen the mounting nuts.
- Remove the casing of the air filter.

## AGML Uninstalling / installing engine mount

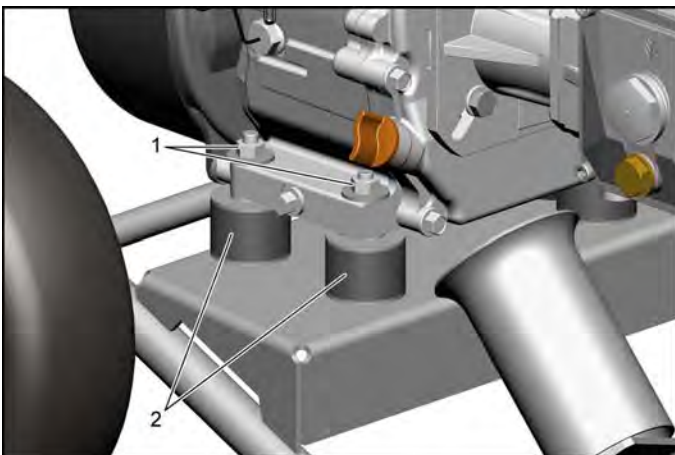

- 1 Motor bearing
- 2 Nuts

- Loosen the mounting nuts.
- Lift engine.
- Replace engine mount in pairs.
- Repeat process on the opposite side.

## AGSF Uninstalling / installing fine sieve fuel tank



### ■ AGKT Uninstalling / installing fuel tank

- 1 Fuel tank
- 2 Fine sieve fuel tank

→ Unscrew the fine sieve of the fuel tank.

## AGSG Uninstalling / installing coarse sieve fuel tank

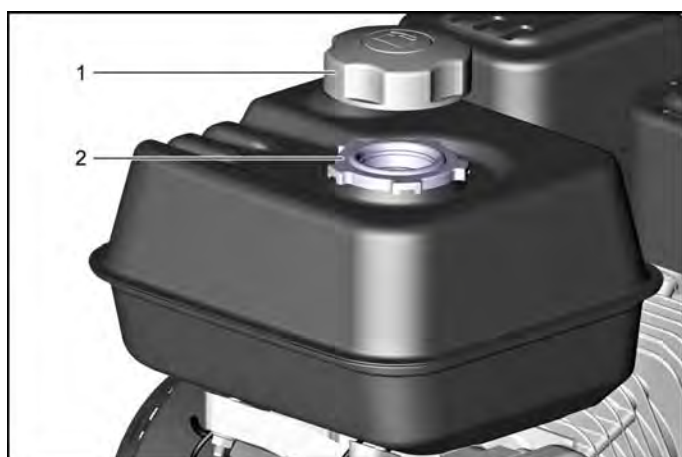

- 1 Reservoir cover
- 2 Coarse sieve fuel tank

→ Remove the tank lid.

→ Remove the coarse sieve of the fuel tank.

## AGVG Uninstalling / installing carburettor

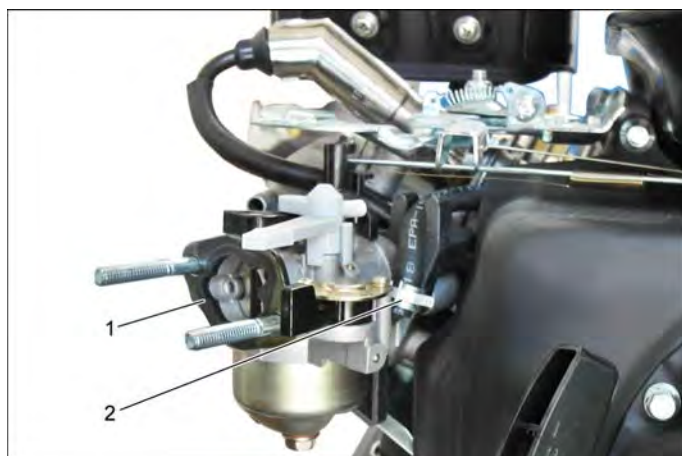

### ■ AGLG Uninstalling / installing casing of the air filter

- 1 Seal
- 2 Hose

→ Pull out the hose.

→ Remove the seal.

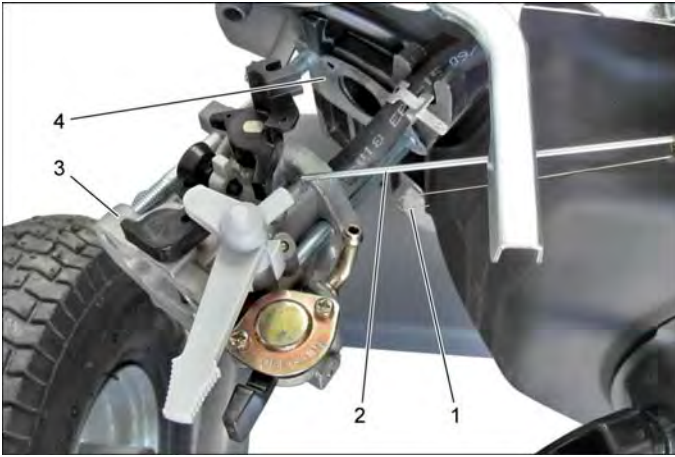

- 1 Spring
- 2 Linkage
- 3 Carburetor
- 4 Seal

- ➔ Unhook the spring.
- ➔ Unhook linkage.
- ➔ Remove carburettor.
- ➔ Remove the seal.

### AGZK Uninstalling / installing spark plug

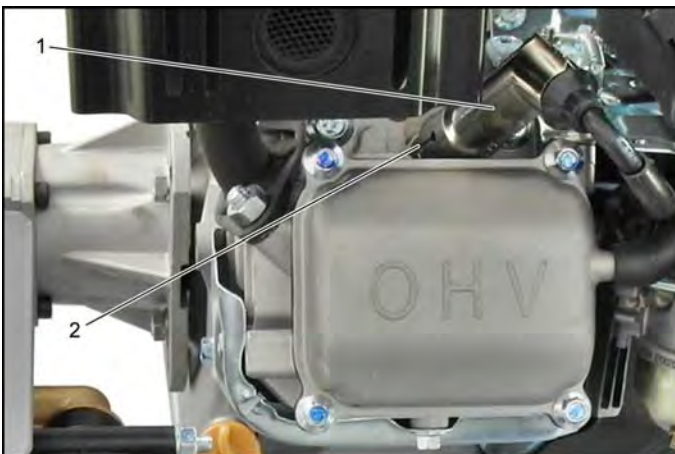

- 1 Ignition plug
- 2 Spark plug

- ➔ Remove spark-plug connector.
- ➔ Unscrew spark plug.

### AGZS Uninstalling / installing ignition coil

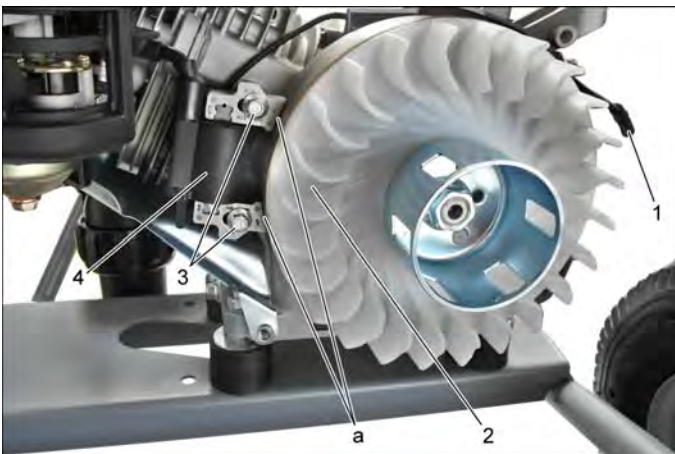

- *AGAL Uninstalling /installing cover fan wheel*
  - *AGLG Uninstalling / installing casing of the air filter*
- 1 Socket plug connection
  - 2 Flywheel
  - 3 Screws
  - 4 Ignition coil

- ➔ Disconnect the connector.
- ➔ Unscrew the screws.

Distance (a)	mm
Between flywheel and ignition coil	0,4 +/- 0,2

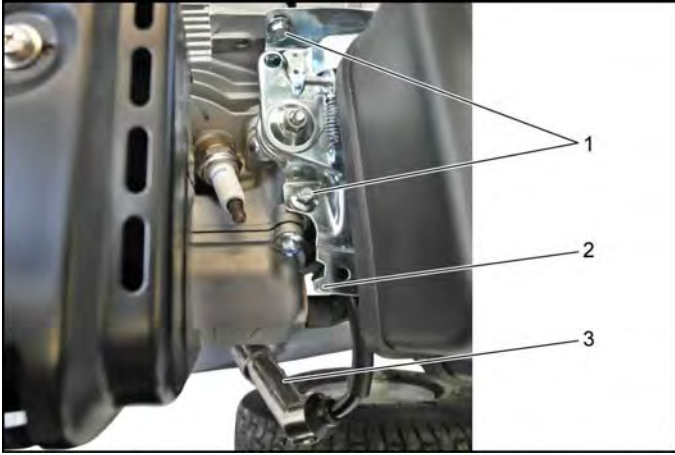

- 1 Screws
- 2 Plate
- 3 Ignition plug

- ➔ Unscrew the screws.
- ➔ Remove spark-plug connector.
- ➔ Pass the spark plug connector underneath the plate.
- ➔ Remove the ignition coil with the connection cables.

## 050 Maintenance and inspection

### AGMO Changing the engine oil

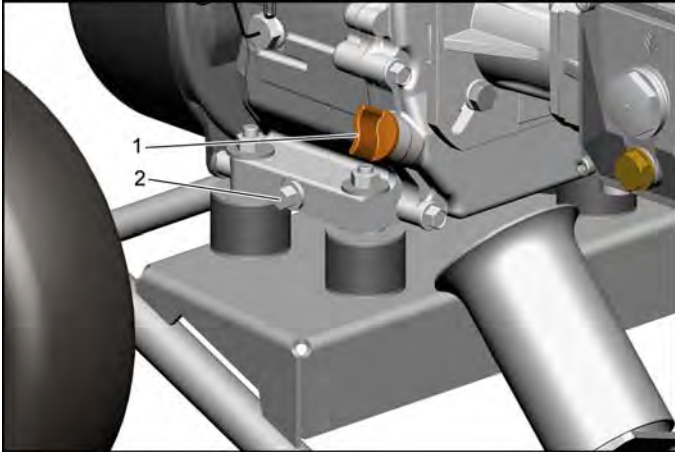

- 1 Oil filling screw with oil dipstick
- 2 Oil drain screw

- Remove the oil filling screw with oil dipstick and wipe dipstick clean.
- Unscrew the oil drain screw and collect oil.
- Fix in the oil drain screw and tighten it.
- Park the machine on an even surface.
- Fill in motor oil (SAE 10 W/30) up to the lower edge of the oil fill opening.  
(For maximum filling quantity refer to "Technical data").
- Screw in oil filling screw.

#### Note

Perform oil change when the engine is warm.

### Setting the motor rpm



- 1 Gas lever

- Push the accelerator lever all the way to the left.

### Setting the idling speed

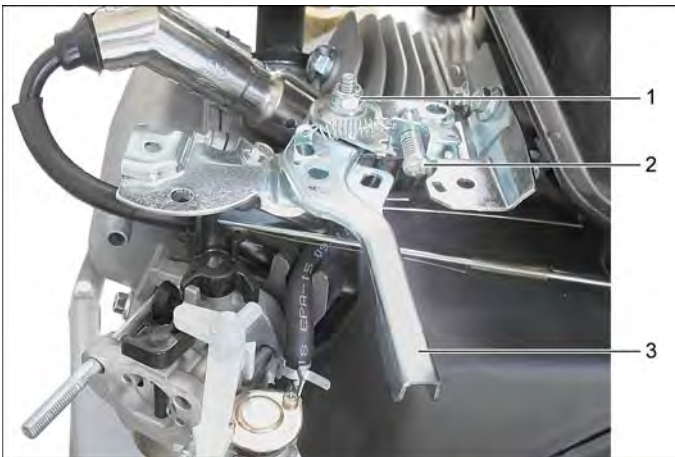

- 1 Nut
- 2 Adjustment screw idling speed
- 3 Gas lever

- Install the high pressure nozzle.  
Refer to chapter "Technical data".
- Start the engine and let it warm up.
- Push the accelerator lever to the left up to the stop.
- Adjust the idling speed with the adjustment screw idling speed.  
Refer to chapter "Technical data".
- Open the hand spray gun.
- Check if the accelerator lever is all the way at the left stop.
- Open and close the trigger gun 3 times.  
Check the idling and operating speed respectively.  
Refer to chapter "Technical data".
- Turn off the appliance.
- Seal the adjustment screw idling speed by means of locking paint.
- Tighten the screw and secure it by means of locking paint.

#### Note

Shown on the device with uninstalled air filter.

#### Note

In the normal unit operation the accelerator lever is not re-adjusted.

Use special tools.

## **Cleaning the sediment cup**

### ■ *AGAB Uninstalling / installing sediment cup*

- Close fuel cock.
- Unscrew the sediment cup.
- Remove O-ring.
- Clean the sediment cup and the O-ring using non-flammable solvent and allow them to dry.
- Insert the O-ring into the fuel cock.
- Screw in the sediment cup and tighten it.
- Open fuel cock
- Check sediment cup for leaks.
- Replace the O-ring in case of leaks.

## **Check spark plug**

### ■ *AGZK Uninstalling / installing spark plug*

- Remove spark-plug connector.
- Clean the spark plug and the surroundings.
- Unscrew spark plug.
- Replace spark plugs with worn electrodes or broken insulator.
- Check the distance between the electrodes of the spark plug.
- For target values refer to technical specifications.

### **ATTENTION**

*A loose spark plug can overheat and damage the engine.*

*A spark plug that is excessively tightened damages the thread in the cylinder head.*

*Observe the information on tightening the spark plug.*

- Carefully screw in the spark plug by hand. Do not cant the thread.
- Turn the spark plug up to the stop using the spark plug wrench and tighten it as follows:
  - Tighten used spark plugs with 1/8...1/4 rotation.
  - Tighten new spark plug with 1/2 rotation.
- Push on spark-plug connector.

## Carburettor modification for operation in higher altitudes

- When operating the device at a high altitude, the standard carburettor air-fuel mix is too rich.
  - The performance decreases and the fuel consumption increases.
  - A very rich air-fuel mix leads to faster soiling of the spark plugs and aggravated start-up of the engine.
  - When operated at an altitude for which this engine has not been certified, there is an increased exhaust emission.
  - The operation at higher altitudes can be improved by adjusting the carburettor jet.
  - If the engine is to be used at altitudes above 1500 metres, perform these carburettor modifications.
  - This way the exhaust emission standard is met during the entire service life.
- Even with a carburettor modification the engine performance decreases approx. 3.5 % for every 300 metres of increase in altitude.
  - The effect of the altitude on the engine performance is even bigger if no carburettor modification has been performed.

### Note

If the carburettor was modified for the operation in higher altitudes, the air-fuel mix is too lean for lower altitudes. If the engine is operated with a modified carburettor at altitudes below 1500 metres, the engine can overheat and lead to severe engine damage.

## Carburettor modification



### Perform nozzle change:

- 1 Sediment cup
- 2 Screw

- Loosen the screw.
- Remove sediment cup.



- 1 Screwdriver
- 2 Nozzle

- Unscrew the nozzle by means of a screwdriver.

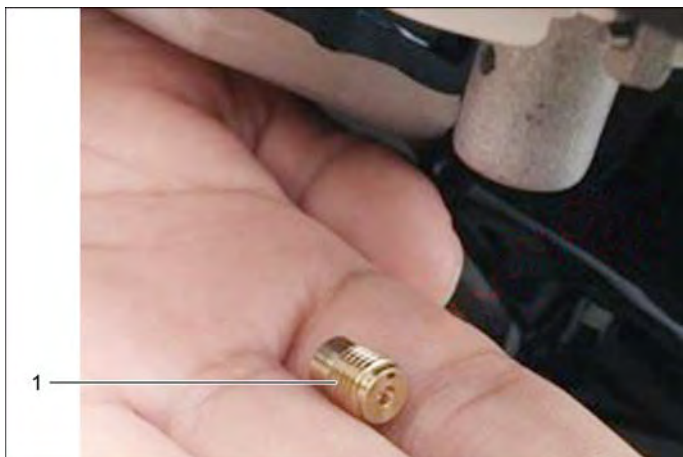

- 1 Nozzle

- Replace nozzle.

### Note

- Renew seals.
- Additional adjustment work on the engine and carburettor are not necessary.

## Use of fuel with additives

- Some fuel types are mixed with alcohol or ether compounds.
- The use of fuel with additives helps to reduce emissions.
- If fuels with additives are used, it must be ensured that the fuel is unleaded and the minimum octane number is met.
- The following fuels with additives are approved:

- Ethanol

Fuel that contains up to 10% ethanol can be used.

- MTBE (Ether)

Fuel that contains up to 15% MTBE (ether) can be used.

- Methanol

Fuel that contains up to 5% methanol can be used as long as it contains anti-corrosion agents for the protection of the fuel system.

Fuel with more than 5% methanol can cause starting problems or loss in performance.

This fuel can damage metal, rubber and plastic parts of the fuel system.

### Note

- If unwanted implications are detected, the fuel of another supplier should be used.
- If fuel is used that has not been approved, the fuel system can get damage or a loss in performance may occur.

## 060 Error diagnosis

Fault	Cause	Remedy
Engine does not start	Motor switch has been switched off.	Switch on engine switch.
	Fuel cock closed.	Open fuel cock.
	Choke opened.	Close choke when engine is warm.
	Lack of fuel	Refill the fuel tank.
	Wrong or old fuel.	Drain the fuel tank and the carburettor. Fill appropriate, fresh fuel in the tank.
	Spark plug soiled, distance between electrodes incorrect.	Clean the spark plug. Check spark plug for damage and distance between the electrodes.
	Spark plug is defective.	Replace the spark plug.
	Spark plug wet.	Dry spark plug and screw it back in.
Reduced motor output	No ignition spark	Check ignition coil and wiring.
	Air filter is dirty.	Check the air filter, clean if required.
	Lack of fuel	Refill the fuel tank.
Compression too low or does not exist.	Wrong or old fuel.	Drain the fuel tank and the carburettor. Fill appropriate, fresh fuel in the tank.
	Spark plug is not properly tightened.	Tighten the spark plug.

## 070 Peculiarities/ others

The service group does not contain any peculiarities.



### 010 Safety information

#### General

Observe general safety information!

Service and maintenance tasks may only be performed by qualified and specially trained specialists.

#### **⚠ DANGER**

- Switch off the appliance and, in case of appliances connected to the mains, pull out the power cord before cleaning and performing any maintenance tasks on the machine.
- Relieve the high pressure system of all pressure prior to all work on the appliance and the accessories.
- Maintenance work may only be carried out by approved customer service outlets or experts in this field who are familiar with the respective safety regulations.
- To avoid risks, all repairs and replacement of spare parts may only be carried out by the authorised customer service personnel.
- Only use accessories and spare parts which have been approved by the manufacturer. The exclusive use of original accessories and original spare parts ensures that the appliance can be operated safely and trouble free.

### 020 Overview

#### Electrical system

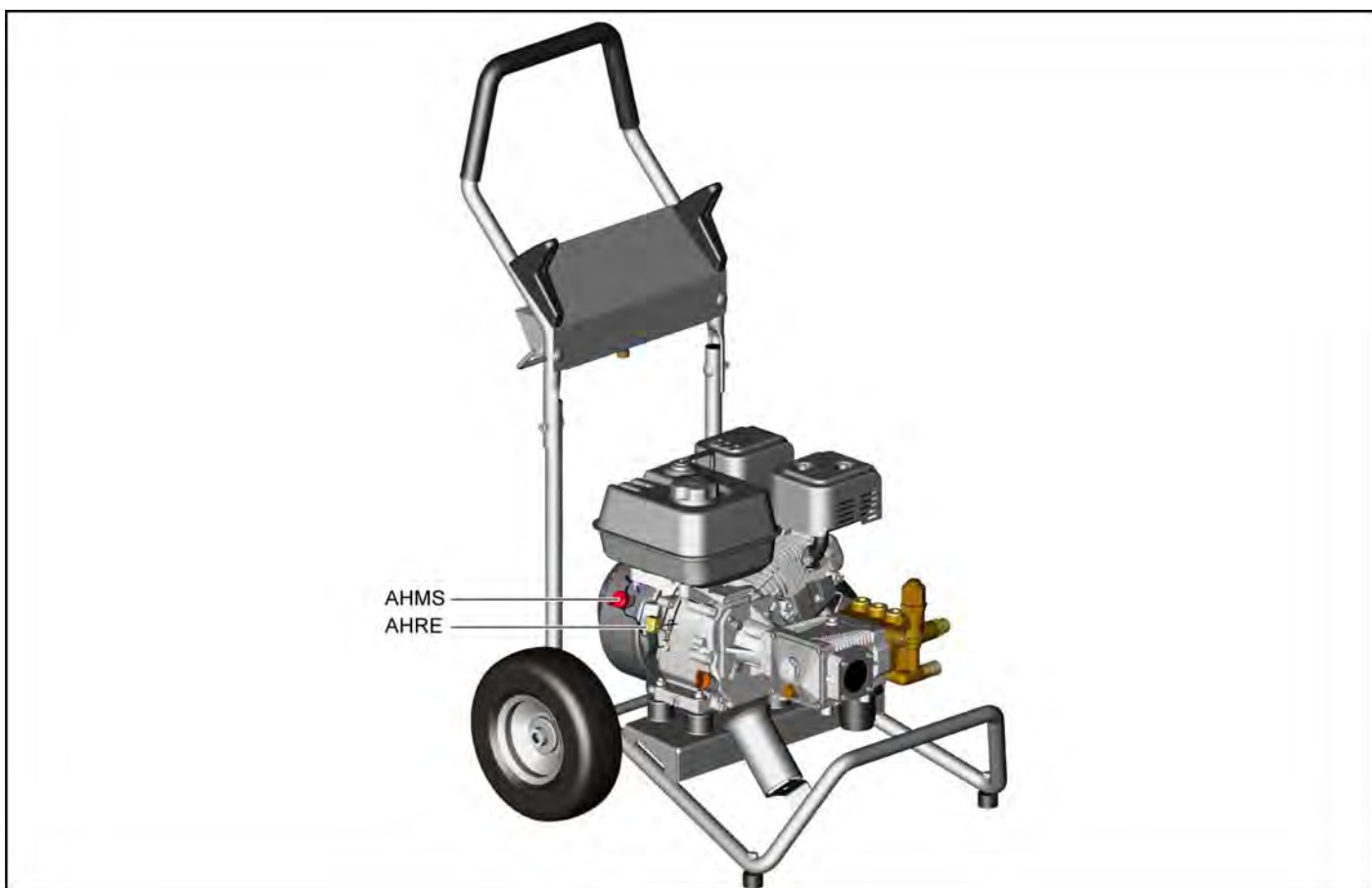

AHMS Uninstalling / installing starter

AHRE Uninstalling / installing relay low oil level

## 040 Service activities

### Note

Unless otherwise described, the installation takes place in reverse order.

### AHMS Uninstalling / installing starter

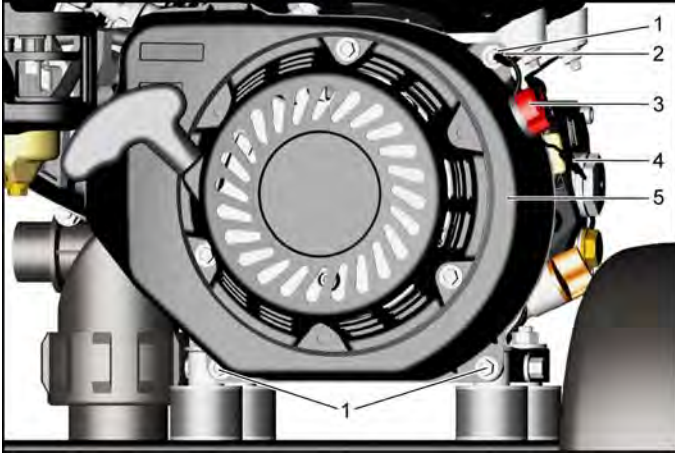

- 1 Screws
- 2 Ground cable
- 3 Engine switch
- 4 Plug connections
- 5 Cover of fan wheel

- ➔ Disconnect the connectors.
- ➔ Unscrew the screws.
- ➔ Remove earth cable.
- ➔ Remove the cover of the fan wheel.

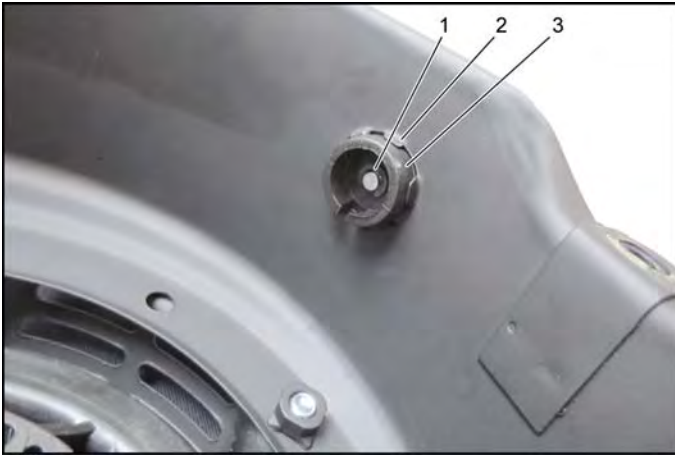

- 1 Safety ring
- 2 Halting plate
- 3 Casing starter

- ➔ Remove the retaining ring.
- ➔ Remove starter.
- ➔ Bend up holding plate.
- ➔ Pull out the casing of the starter.

### AHRE Uninstalling / installing relay low oil level

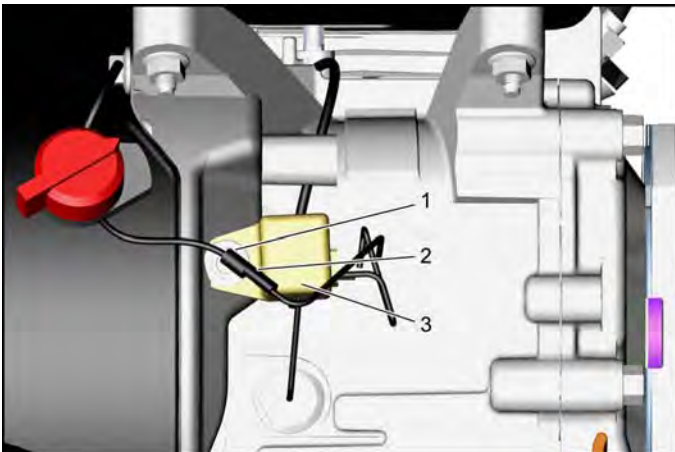

- 1 Screw
- 2 Plug connections
- 3 Relay low oil level

- ➔ Loosen the screw.
- ➔ Disconnect the connectors.
- ➔ Remove the low oil level relay.

## 050 Maintenance and inspection

Service group does not contain any maintenance and inspection points.

## 060 Error diagnosis

The service group does not contain any error diagnosis.

## 070 Peculiarities/ others

The service group does not contain any peculiarities.

# Technical Documentation

## Technical specifications

		HD 6/12 G	HD 6/15 G	HD 7/20 G	HD 8/23 G
<b>Internal combustion engine</b>					
Power	kW	4,1		5,2	6,8
Cylinder diameter	mm	68		75	80
Piston stroke	mm	54		57	60
Spark plug		F7RTC			
Contact clearance	mm	0,7...0,8			
Valve clearance with cold engine	mm	0,1...0,15			
Dry run speed	1/min	3450 +/- 50	3600 +/- 50	3700 +/- 50	
Operating speed (trigger gun opened)	1/min	3300 +/- 100	3400 +/- 100	3500 +/- 100	
Engine oil - type		SAE 10 W30			
Amount of oil	l	0,6		0,7	0,95
Engine type		G200-FA		G250-FA	G300-FA
Engine manufacturer		Loncin			
Cylinder capacity	cm <sup>3</sup>	196		252	302
Fuel		unleaded vehicle petrol (86 ROZ)			
may use E10 petrol		no			
Tank content	l	3		4	5,5
Type of protection		IPX5			
<b>Pump</b>					
Test nozzle	Size	18			27
Amount of oil	l	0,4			
Oil type - pipe		Engine oil 15W40			
Oil temperature (max.)	°C	75			
High pressure nozzle	Size	42	38	36	40
Flow rate	l/h	> 550		> 650	> 750
Working pressure	MPa (bar)	12 (120)	15 (150)	20 (200)	23 (230)
Opening pressure safety valve	MPa (bar)	16...18 (160...180)	19...21 (190...210)	24...26 (240...260)	27...29 (270...290)
Opening pressure overflow valve	MPa (bar)	13,6...14,0 (136...140)	16,0...16,4 (160...164)	21,2...21,6 (212...216)	22,4...22,8 (224...228)
<b>Water connection</b>					
Max. feed temperature	°C	60			
Min. feed volume	l/h (l/min)	780 (13)		900 (15)	1040 (17)
Max. feed pressure	MPa (bar)	1 (10)			
Suck height from open container (20 °C)	m	1			
<b>Dimensions and weights</b>					
Length x width x height	mm	799x637x1097			
Weight	kg	44		45	54
<b>Values determined as per EN 60335-2-79</b>					
Hand-arm vibration value	m/s <sup>2</sup>	1,8	2,3	2,9	3,5
Uncertainty K	m/s <sup>2</sup>	0,7		0,8	
Sound pressure level L <sub>pA</sub>	dB(A)	85		88	91
Uncertainty K <sub>pA</sub>	dB(A)	3			
Sound power level L <sub>WA</sub> + Uncertainty K <sub>WA</sub>	dB(A)	102		105	108

## Maintenance overview report

### ⚠ WARNING

Prior to starting care or maintenance work, allow the engine to cool down. In order to avoid an accidental start-up of the engine, remove the spark plug connector.



To avoid risks, all repairs and replacement of spare parts may only be carried out by the authorised customer service personnel.

➔ Park the machine on an even surface.

	Every 6 months Every 100h	Yearly Every 300h	Every 2 years
Clean sediment cup.	X		
Check and adjust the idling speed.		X	
Check and adjust the tappet clearance.		X	
Clean fuel tank and fuel filter.		X	
Check the fuel line, replace if necessary.			X

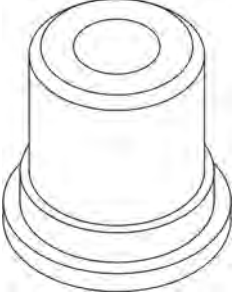
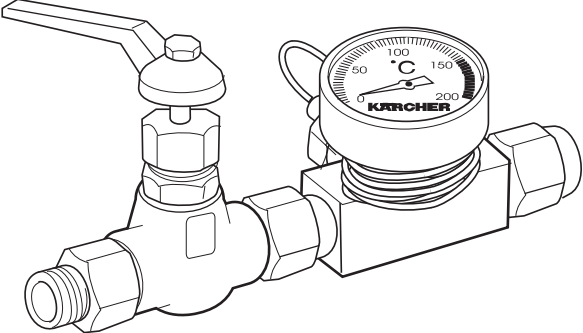
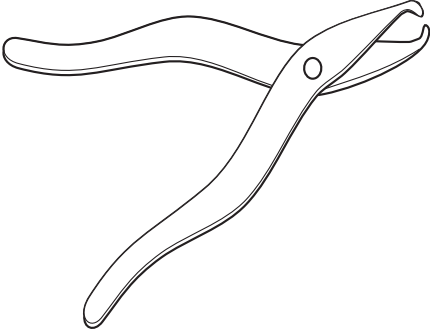
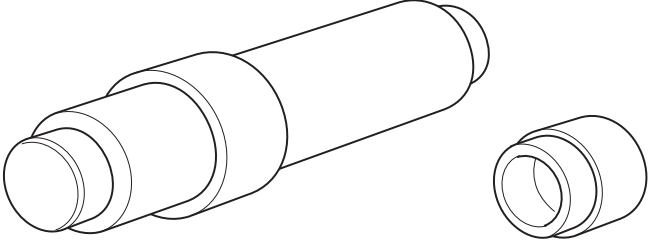
## Special tools

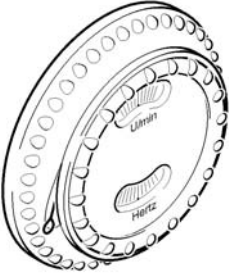
			
HD 6/12, HD 6/15, HD 7/20 Test nozzle 25018  HD 8/23 Test nozzle 25027	5.765-092.0  5.765-005.0	Shut-off valve with thermometer	2.901-030.0
			
Removal pliers, pressure/suction valves and water sieves	4.901-062.0	Installation mandrel oil seal Connecting rod diameter = 18 mm	2.901-033.0
		Installation mandrel high pressure gasket Piston diameter = 15 mm	5.901-024.0
		Installation sleeve, high pressure seal Piston diameter = 15 mm	5.901-023.0

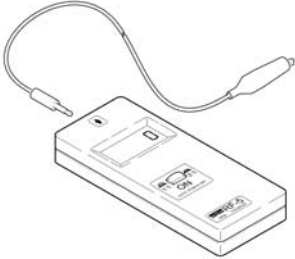
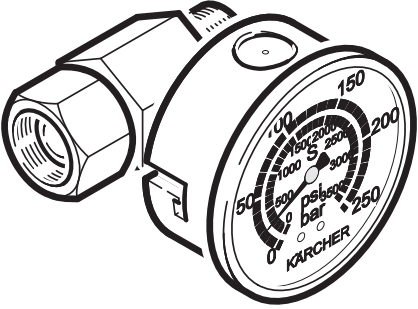
			
<p>Mechanical rev counter</p>	<p>6.491-361.0</p>	<p>Digital rev counter with operating hours counter</p>	<p>6.681-109.0</p>
			
<p>Digital rev counter</p>	<p>6.803-012.0</p>	<p>Test manometer for working pressure</p>	<p>4.401-072.0</p>

## Circuit diagram

When working on the device, please always use the current circuit diagram in DISIS.

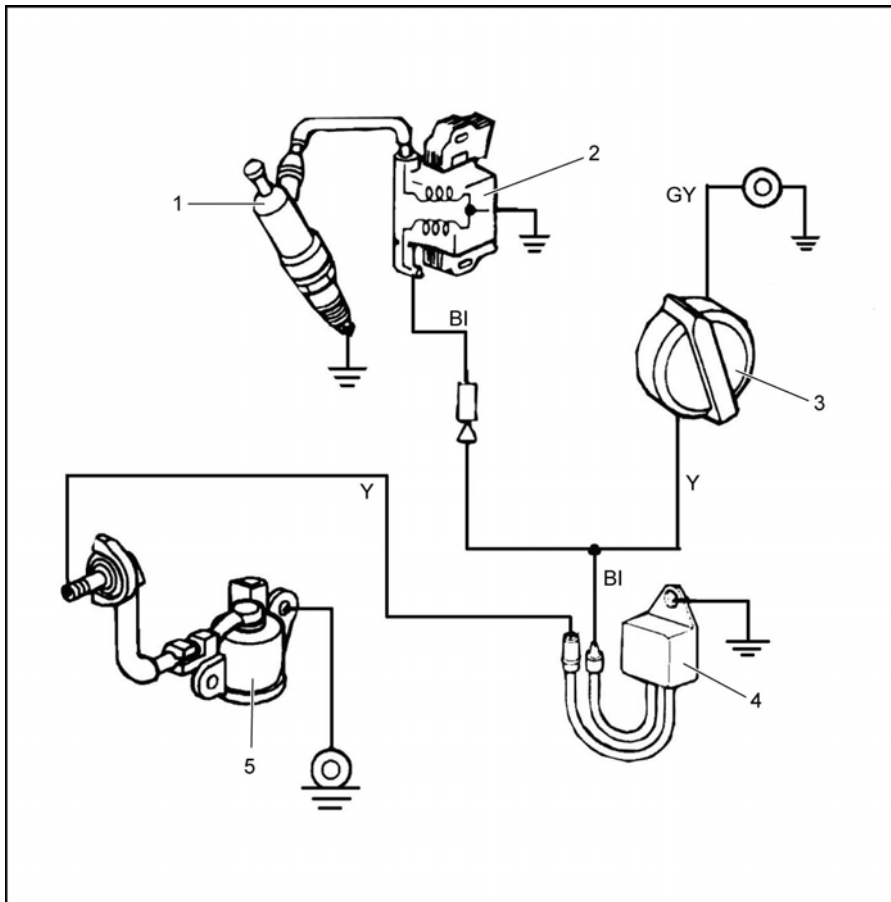

Component	
1	Spark plug
2	Ignition coil
3	Engine switch
4	Relay low oil level
5	Oil level switch

Cable colours	
BI	Black
Y	Yellow
GY	Green/Yellow